

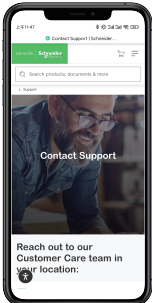

Customer Care Center



Reach out to our Customer Care team in your location:

The image shows a QR code on the left and a smartphone on the right displaying the Schneider Customer Support app. The app screen shows a search bar, a 'Contact Support' button, and a message: 'Reach out to our Customer Care team in your location:'. The smartphone screen also shows the time 14:14 and the text 'Contact Support | Schneider'.

Safety	3
1 Contents	4
2 Description	5
2.1 Product References and Characteristics.....	5
2.2 Product Description of ATC.....	5
2.2 Product Description of T2S	6
2.3 Inside View	7
2.4 Label	7
3 Characteristics	7
3.1 General Data	7
3.2 Certification	8
3.3 Environment	8
3.4 Accessories	8
4 Protection	8
4.1 Upstream Protections.....	8
4.2 Distribution System Operator (DSO).....	8
4.3 Power Cable Requirements	8
5 Electrical Diagram	9
6 Steps to Install the Charging Station	10
7 Installation	11
7.1 Equipment Supplied by User.....	11
7.2 Tools Supplied by User	11
7.3 Wall Mounting	11
7.4 Wiring	14
7.5 Cable Locker	19
7.6 Mini SIM Card Insertion.....	20
7.7 Installation Complete.....	20
8 Connection	21
8.1 Wire-up Signal Line	21
8.2 Wire-up Power Supply	22
9 Inspection	23
10 Communication Feature	23
10.1 RFID	23
10.2 Ethernet Port	23
10.3 Modbus RTU	23
10.4 GSM, UMTS and LTE Network Interface	23
11 Energy Management (For Charge Pro with TIC Function)	23
12 External Power Meter	23
12.1 PowerTag Energy Resi9	23
12.2 P1 Smart Meter and P1MB Gateway	24
13 Operation	24
13.1 Connecting the Electric Vehicle Charging Station.....	24
13.2 Disconnecting the Electric Vehicle	24
14 Test with a Vehicle Simulator	24
15 Cable Storage	25
16 Reset to Factory	26
16.1 Operation by eSetup Application.....	26
16.2 Operation by Dip Switch.....	26
17 Charging Station Indicators	30
17.1 Front LED Color	30
17.2 Side LED Color	31
18 Recycle	31

The information provided in this document contains general descriptions, technical characteristics and/or recommendations related to products/solutions.

This document is not intended as a substitute for a detailed study or operational and site-specific development or schematic plan. It is not to be used for determining suitability or reliability of the products/solutions for specific user applications. It is the duty of any such user to perform or have any professional expert of its choice (integrator, specifier or the like) perform the appropriate and comprehensive risk analysis, evaluation and testing of the products/solutions with respect to the relevant specific application or use thereof.

The Schneider Electric brand and any trademarks of Schneider Electric SE and its subsidiaries referred to in this document are the property of Schneider Electric SE or its subsidiaries. All other brands may be trademarks of their respective owner.

This document and its content are protected under applicable copy right laws and provided for informative use only. No part of this document may be reproduced or transmitted in any form or by any means (electronic, mechanical, photocopying, recording, or otherwise), for any purpose, without the prior written permission of Schneider Electric.

Schneider Electric does not grant any right or license for commercial use of the document or its content, except for a non-exclusive and personal license to consult it on an "as is" basis.

Schneider Electric reserves the right to make changes or updates with respect to or in the content of this document or the format thereof, at any time without notice.

To the extent permitted by applicable law, no responsibility or liability is assumed by Schneider Electric and its subsidiaries for any errors or omissions in the informational content of this document, as well as any non-intended use or misuse of the content thereof.

Electrical equipment should be installed, operated, serviced, and maintained only by qualified personnel. No responsibility is assumed by Schneider Electric for any consequences arising out of the use of this material.

Safety

Important Information



Read these instructions carefully, and look at the equipment to become familiar with the device before trying to install, operate, or maintain it. The following special messages may appear throughout this documentation or on the equipment to warn of potential hazards or to call attention to information that clarifies or simplifies a procedure.



The addition of this symbol to a "Danger" or "Warning" safety label indicates that an electrical hazard exists which will result in personal injury if the instructions are not followed.



This is the safety alert symbol. It is used to alert you to potential personal injury hazards. Obey all safety messages that follow this symbol to avoid possible injury or death.

▲ DANGER

DANGER indicates a hazardous situation which, if not avoided, **will result in death** or serious injury.

▲ WARNING

WARNING indicates a hazardous situation which, if not avoided, **could result in death** or serious injury.

▲ CAUTION

CAUTION indicates a hazardous situation which, if not avoided, **could result in minor or moderate injury**.

NOTICE

NOTICE is used to address practices not related to physical injury.

PLEASE NOTE

- All applicable local, regional and national regulations must be complied with during the installation, use, maintenance and replacement of this device.
- Schneider Electric cannot be held responsible in the event of non-compliance with the instructions in this document and in the documents to which it refers.
- The service instruction must be observed throughout the life time of this device.
- If it is connected to EV Charging Expert, the update of the charging station will be automatically performed by EV Charging Expert when configuring the system (check beforehand that EV Charging Expert is up to date).

▲ ▲ WARNING





RISK OF INJURY OR DAMAGING THE CHARGING STATION

- The installation, maintenance and eventual replacement of this device must only be carried out by a qualified electrician.
- This device must not be repaired.
- This device should not be installed if, when unpacking it, you observe that it is damaged.
- The charging station, the cable and the connector must be regularly checked by to detect any potential damage (visual inspection).
- In case the charging station is damaged, it must be immediately turned off and replaced.
- Do not remove signs such as safety symbols, warnings, nameplates, signs or markings.
- Do not connect any other type of loads to the charging station (power tools, etc.). Only connect electric vehicles or their charging equipment.
- Do not disconnect the connector by pulling the cable. Hold the connector in your hand to disconnect the connector from the electrical vehicle.
- Do not bend, squeeze or tilt the connector so that it is mechanically damaged.
- Prevent the connector to be in contact with heat source, dirt or water.
- Never clean the charging station by spraying it with water (Hose for garden watering, high pressure cleaners, etc.).
- Never clean the charging station by chemical or aggressive cleaner.

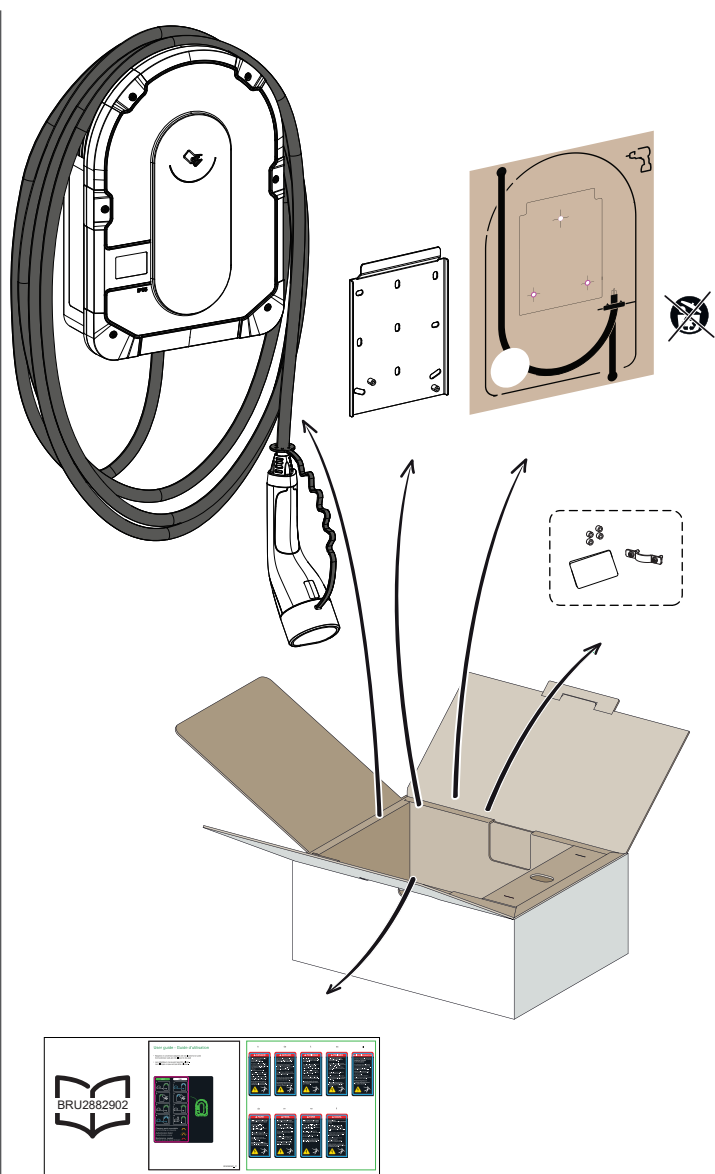
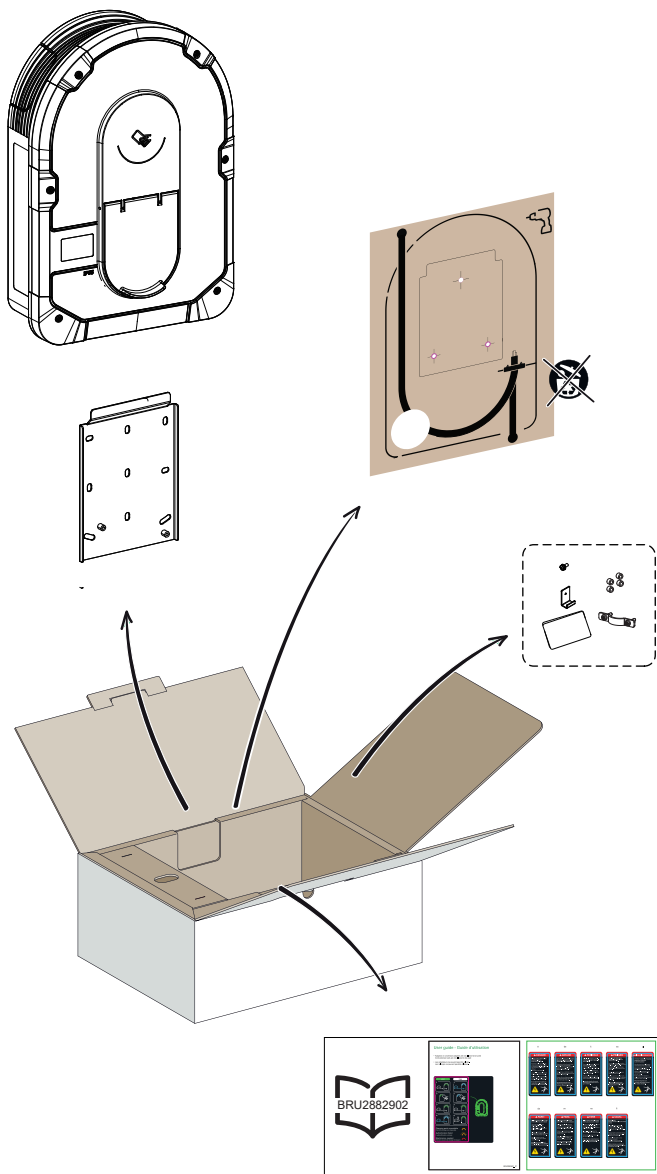
Failure to follow these instructions could result in death, serious injury, or equipment damage.

1 Contents



	Spacer × 4 (1)		Clamp-big × 1 (2)
	Cable locker × 1 (3)		Locker screw × 1 (3)
	RFID badge × 2		

- (1) Only used for installation on irregular wall.
 (2) Used for power cable 20-23 mm.
 (3) Only available for T2S Chargers, please refer to section 2.1 for specific reference numbers.

2 Description

2.1 Product References and Characteristics

Commercial Reference	Number of Phase	Current output (A)	Power Rating (kW)	Type EV socket	Cable Locker	4G	Wi-Fi	TIC	MID	Countries	CE	Agencies
EVB4S22N40M	1/3	32	7/11/22	T2S	■		■	■	■	France + Others	■	IEC
EVB4S22N40	1/3	32	7/11/22	T2S	■		■	■		France + Others	■	IEC
EVB4S22NC0M	1/3	32	7/11/22	Attached Cable			■	■	■	Others	■	IEC
EVB4S22NC0	1/3	32	7/11/22	Attached Cable			■	■		Others	■	IEC
EVB4S22N40MG	1/3	32	7/11/22	T2S	■	Integrated	■	■	■	France + Others	■	IEC
EVB4S22N40G	1/3	32	7/11/22	T2S	■	Integrated	■	■		France + Others	■	IEC
EVB4S22NC0MG	1/3	32	7/11/22	Attached Cable		Integrated	■	■	■	Others	■	IEC
EVB4S22NC0G	1/3	32	7/11/22	Attached Cable		Integrated	■	■		Others	■	IEC

2.2 Product Description of ATC

- This charging station is an electrical appliance that supplies electric energy to charge plug-in electric vehicles for indoor and outdoor areas.
- When installing and using the charging station, ensure that you comply with local regulations.
- The intended use of the equipment includes, in all cases, the environmental conditions established for the equipment.

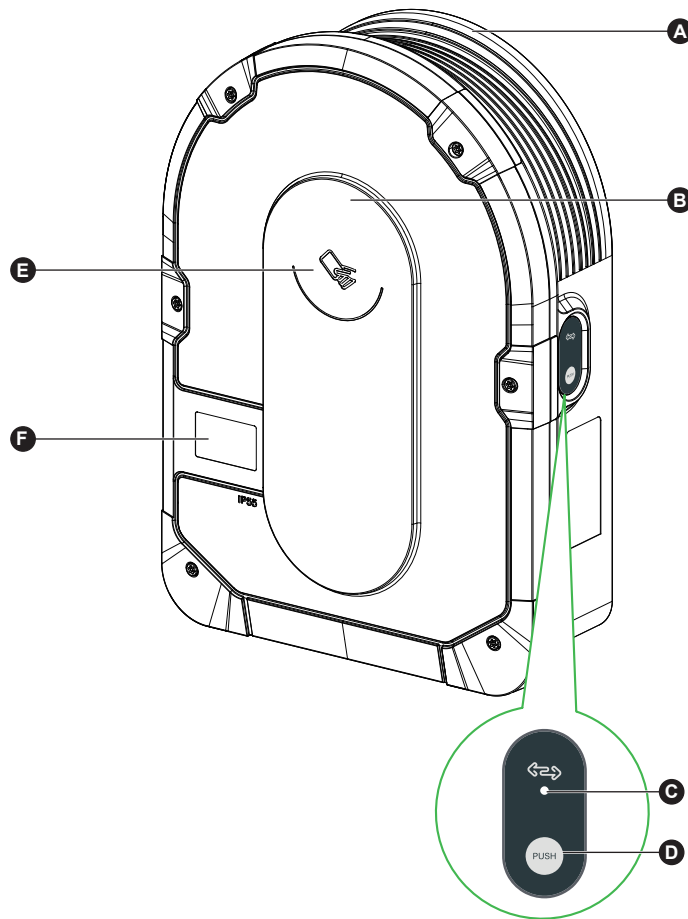

A	Cable winding trough	When not in use, wrap the charging cable around the charging station's trough to avoid tripping hazards and equipment damage.
B	Front indicator light	Indicates the status of the charging station and charging session, section "Charging Station Indicators", page 30.
C	Side indicator light	Indicates status during Wi-Fi access point commissioning and anti-tripping module pairing, section "Charging Station Indicators", page 31.
D	Functional button	Press to enable Wi-Fi access point/Reset PIN Code/anti-tripping module pairing (power off and then back on the product to enable this button).
E	RFID reader	Once card is swiped on swiping area of RFID reader, a charging session will start. During charging, charging session could be stopped by swiping the card.
F	MID meter*	Scrolling displays the index of charging information such as phase voltage/current/power/energy.

* Only available for MID versions, please refer to section 2.1 for specific reference numbers.

2 Description

2.2 Product Description of T2S

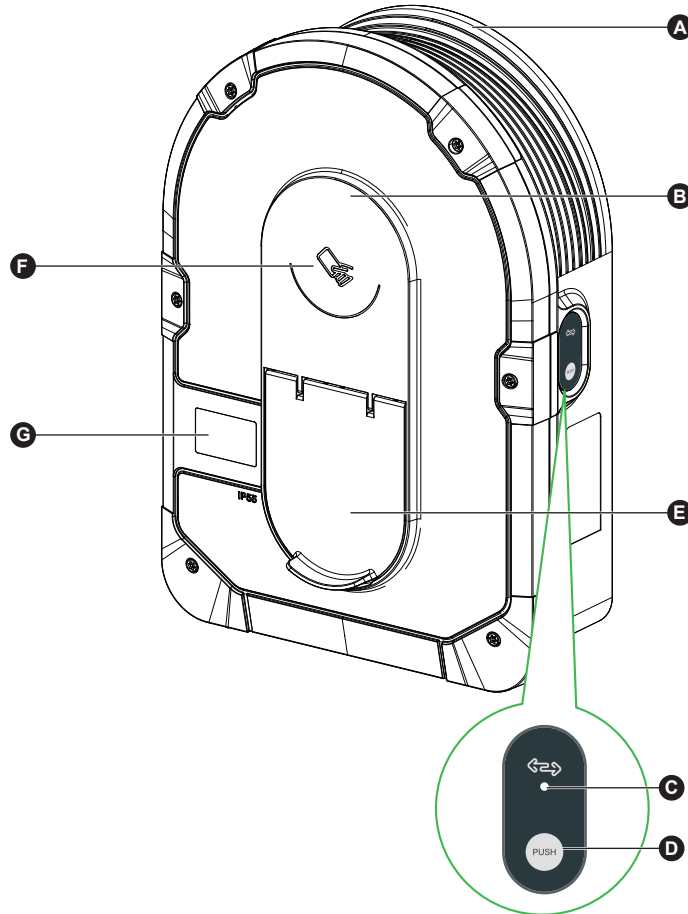

A	Cable winding trough	When not in use, wrap the charging cable around the charging station's trough to avoid tripping hazards and equipment damage.
B	Front indicator light	Indicates the status of the charging station and charging session, section "Charging Station Indicators", page 30.
C	Side indicator light	Indicates status during Wi-Fi access point commissioning and anti-tripping module pairing, section "Charging Station Indicators", page 31.
D	Functional button	Press to enable Wi-Fi access point/Reset PIN Code/anti-tripping module pairing (power off and then back on the product to enable this button).
E	Charging socket	Plug in your T2 charging cable.
F	RFID reader	Once card is swiped on swiping area of RFID reader, a charging session will start. During charging, charging session could be stopped by swiping the card.
G	MID meter*	Scrolling displays the index of charging information such as phase voltage/current/power/energy.

* Only available for MID versions, please refer to section 2.1 for specific reference numbers.

2 Description

2.3 Inside View

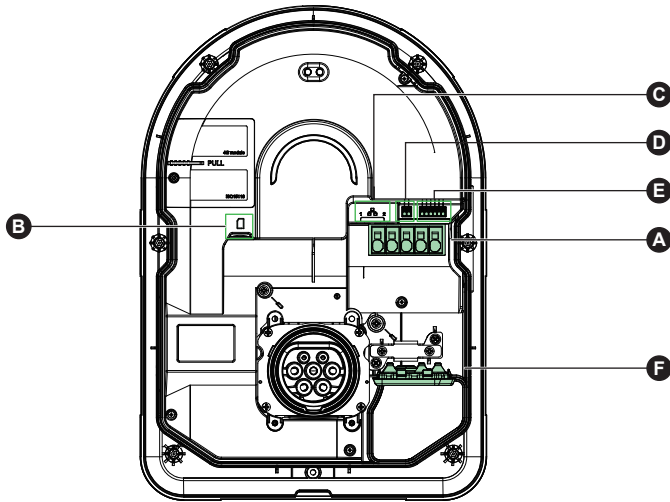

- A** Ground & Power terminal bloc
- B** Mini SIM card slot
- C** Ethernet ports Eth1/Eth2
- D** Connectors for iMNx
- E** Connectors for TIC/DSO/RS485
- F** Input/cable gasket

2.4 Label

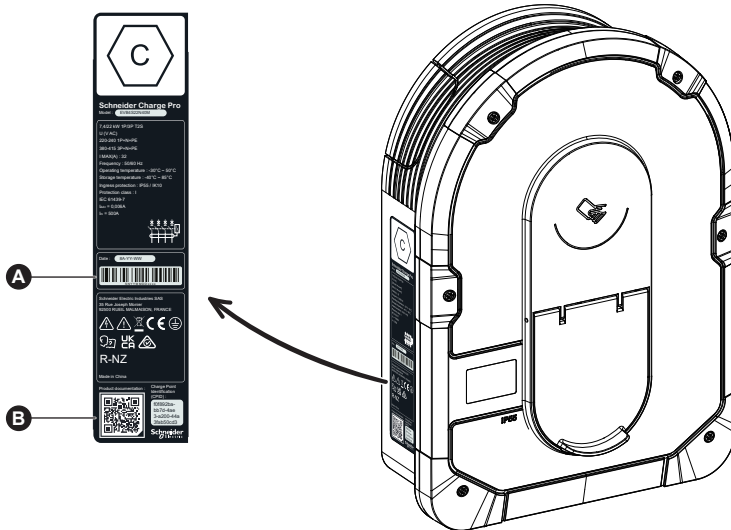

- A** Serial number
- B** QR code of Go2SE to access device information

3 Characteristics

3.1 General Data

- Ingress protection rating: IP55 (IEC 60529)
- Impact protection rating: IK10 (IEC 62262)
- Socket for T2 cable or T2 attached cable according to IEC 62196-1 and IEC 62196-2
- Operating temperature (1):
 - -30°C to +50°C for Schneider Charge Pro with T2S socket (-22°F to +122°F) (± 30)
 - -30°C to +50°C for Schneider Charge Pro with attached cable (-22°F to +122°F) (± 30)
- Storage temperature: -40°C to +85°C (-40°F to +185°F)
- Relative humidity: 5-95 %
- Rated voltage (depending on model):
 - For 7.4 kW: 220-240V AC +/- 10 %, 50/60 Hz
 - For 22 kW: 380-415V AC +/- 10 %, 50/60 Hz
- Rated charging current: 32A for 7.4 kW, 16A for 11 kW and 32A for 22 kW
- Accuracy of current, voltage, power and energy measurement: 1 %
- Diagram of the earthing system: TN-S, TN-C-S, TT, IT (only 220-240V)
- Designed for indoor and outdoor use
- OCPP 1.6J
- Wi-Fi feature 2.4 GHz
 - Operating frequency bands: 2412 MHz-2472 MHz
 - WLAN standard: IEEE 802.11 b/g/n
 - Maximal RF output power: less than 20 dBm (18.25 dBm)
- 1 Mini SIM (2)
- 2 Ethernet ports
- 1 RS485 port
- 1 RFID reader
- TIC (3)
- DSO (4)
- iMNx (4)

(1) The charging station embeds a power derating in case of external temperature higher than 50°C, to ensure the continuity of service.

(2) Only available for 4G versions, please refer to section 2.1 for specific reference numbers.

(3) Only available for connection to French utility electronic meters. Please refer to section 11 for more details.

(4) Please refer to section 4 for more details.

3 Characteristics

3.2 Certification

- EN IEC 61851-1
- IEC 61439-7
- IEC 62955
- IEC 61851-21-2
- EN IEC 61000-6-1
- EN IEC 61000-6-2
- EN IEC 61000-6-3
- EN IEC 61000-6-4
- E.V. READY 2.0A
- EN 301 489-1
- EN 301 489-17
- EN 301 489-3
- EN 301 489-52
- EN 300 330
- EN 301 511
- EN 301 908-1
- EN 301 908-2
- EN 301 908-13
- EN IEC 62311
- EN 300 328

3.3 Environment

- Compliant with the RoHS directive
- Compliant with the REACH regulation

3.4 Accessories

- Anti-tripping module (peak controller), single-phase, low rating (EVA4HPC1, 16-50A)
- Anti-tripping module (peak controller), single-phase, high rating (EVA2HPC1, 32-100A)
- Anti-tripping module (peak controller), three-phase, low rating (EVA2HPC3, 16-50A)
- Energy sensor, PowerTag Resi9 80 A 6 circuits LN Modbus (R9M80X6M)
- Energy sensor, PowerTag Resi9 universal 80 A, 160 A, 250 A 6 circuits Modbus (R9MUX6M)
- Resi9 Current Transformer 80 A (R9MCT80), 160 A (R9MCT160), 250 A (R9MCT250)
- Cable Holder (EVA5GH) (For charging station with attached cable)
- Pedestal for 1 Charge Pro (EVA2PBS1)
- Pedestal for 2 Charge Pro (EVA2PBS2)
- Plate to convert pedestal for 1 charging station to pedestal for 2 charging stations (EVA2PCS2)

Notes:

- Please check with local sales for the above accessories' availability in your country, and refer to the instruction sheet of them for use.
- If load management by P1 smart meter is required, XMEX P1MB is recommended as the gateway.
- The anti-tripping module adapt/limits the power draw of the Schneider Charge Pro, **in some cases completely stopping the charging**, to avoid a power outage of your home electrical supply. Schneider Charge Pro provides pairing function with anti-tripping module. Refer to the anti-tripping module's instruction sheet.

4 Protection

4.1 Upstream Protections

- The Electric Vehicle measures the ground resistance and will only start charging if it is lower than the threshold defined by the Electric Vehicle manufacturer. Refer to the vehicle's technical documentation.
- The choice of electrical protections and wire gauges must comply with local regulations and the information below as well as the constraints of the electrical installation. In particular, the selected protection must not only satisfy the requirements of IEC 61851-1 ed 3.0 (1) but must also limit the value of I^2t to less than 75 000 A²s in case of a short-circuit. The minimum values of peak current I_p is 3 kA based on IEC 62955.

(1) According to section 13 of IEC 61851-1 ed 3.0, such over-current protective devices shall comply with IEC 60947-2, IEC 60947-6-2 or IEC 61009-1 or with the relevant parts of IEC 60898 series or IEC 60269 series.

Charging station rated current	32A 1-Phase	16A 3-Phase	32A 3-Phase
Charging station power rating	7.4 kW	11 kW	22 kW
Protection against overload and short circuits	40A curve B or C (2)	20A curve C	40A curve C
Differential protection	30mA type A Si	30mA type A Si	30mA type A Si

(2) According to selectivity with upstream protections

Recommended protection: Acti9 iC60 (If an alternative product is selected, please ensure that it complies with energy limiting class 3.)

- An Undervoltage release (iMNx) controlled by the charging station must be installed to enable to activate the upstream circuit-breaker tripping.
- The protections described above should only be taken as suggestions and it remains the responsibility of the installer to be compliant with the local country regulation.

Recommendations for lightning protection

One surge arrester per charging station is recommended for high keraunic levels, mandatory if required by local regulations.

4.2 Distribution System Operator (DSO)

- According to Technical Connection Rules VDE-AR-N-4100:2019-04 Cl. 10.6.4, a charging station with a total rated power of more than 12 kVA must have a remote power control interface to allow remote Control by the Distribution System Operator (DSO).
 - A dry connector for DSO input to suspend the Schneider Charge Pro.
 - Input connector for DSO cable: 0.2-1.5 mm² (AWG 24-15.5) flex and rigid cable.
 - Schneider charge DSO input supports only Normally Open (NO) configuration:
 - Contact open: Charge allowed
 - Contact closed per the utility: Charge suspended

4.3 Power Cable Requirements

- For wiring section "Wiring", page 14, please comply with local regulations.
- The maximum wire gauge should not exceed 10 mm² (AWG 7).
- Two types of wire as recommended when connecting the charging station to the power supply:
 - To use flexible cables.
 - To use rigid cable.

1-phase installations

	Distribution Board	Undervoltage Release (iMNx)	Distribution System Operator (DSO)
Diameter	3 x 6 mm ² (3 x AWG 9) (Type U1000R2V 3G) (1)	2 x 0.5 mm ² (2 x AWG 20)	2 x 0.5 mm ² (2 x AWG 20)
Length	< 50 meters (164.04 ft)	< 30 meters (98.43 ft)	< 30 meters (98.43 ft)

(1) In some countries (e.g. France) or under certain installation conditions (e.g. wiring through a wall), it can be extended up to 3 x 10 mm² (3 x AWG 7) (Type U1000R2V 3G).

3-phase installations

	Distribution Board	Undervoltage Release (iMNx)	Distribution System Operator (DSO)
Diameter	5 x 6 mm ² (5 x AWG 9) (Type U1000R2V 5G) (2)	2 x 0.5 mm ² (2 x AWG 20)	2 x 0.5 mm ² (2 x AWG 20)
Length	< 50 meters (164.04 ft)	< 30 meters (98.43 ft)	< 30 meters (98.43 ft)

(2) In some countries (e.g. France) or under certain installation conditions (e.g. wiring through a wall), it can be extended up to 5 x 10 mm² (5 x AWG 7) (Type U1000R2V 5G).

⚠️ ⚠️ DANGER

HAZARD OF ELECTRIC SHOCK, EXPLOSION OR ARC FLASH

- Do not install automatic reset systems on the residual current protection device.
- Disconnect the mains power supply before working on the charging station.
- Use a Voltage Tester (VT) of appropriate rating.
- Do not turn on the charging station if the earth resistance measured is higher than the threshold defined in the enforceable regulations.
- The connection to the Under-voltage Release (iMNx) is mandatory.
- Do not connect to an IT earthing system if the voltage exceeds 240Vac
- Install the over-current and residual current protections upstream of charging station.
- It is mandatory to read the detailed instruction sheet of this device and to look at the device to become familiar with it before attempting to install it, operate it, repair it or perform maintenance on it.

Failure to follow these instructions will result in death or serious injury.

NOTICE

INOPERABLE EQUIPMENT

When charging station is powered by 220-240V 3-phase No Neutral, e.g. in Belgium, must do commissioning via eSetup, otherwise upstream MCB tripping may occur.

Failure to follow these instructions could result in equipment damage.

i Ensure that the grounding wire is reliably connected.

i TIC interface is only available for connection to French utility electronic meters. Please refer to section 11 for more details.

380-415V 3-phase With Neutral

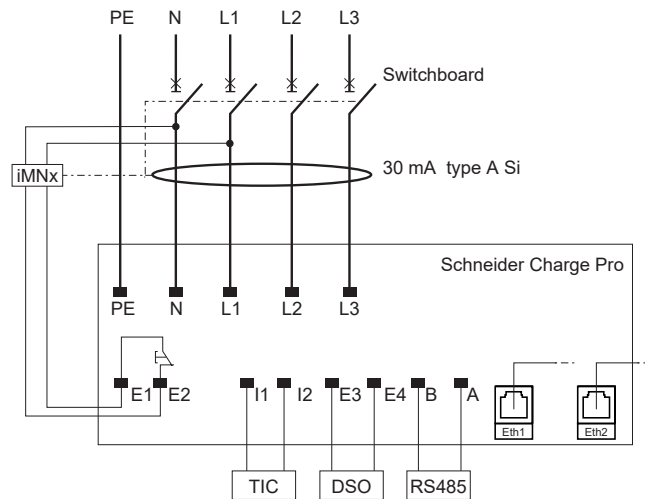

220-240V 3-phase No Neutral

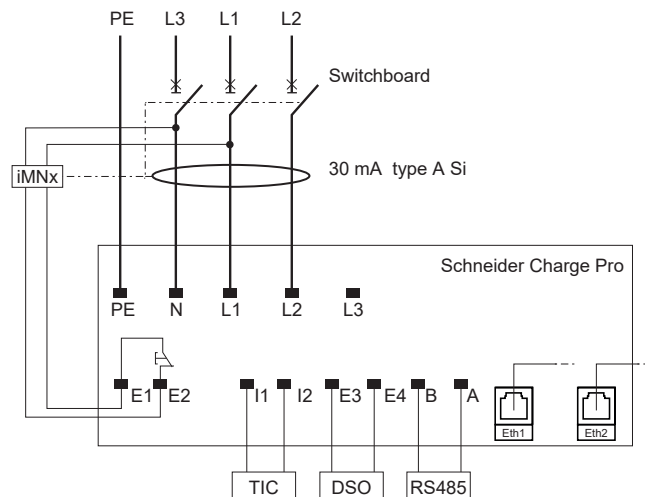

iMNx: Undervoltage release

6 Steps to Install the Charging Station

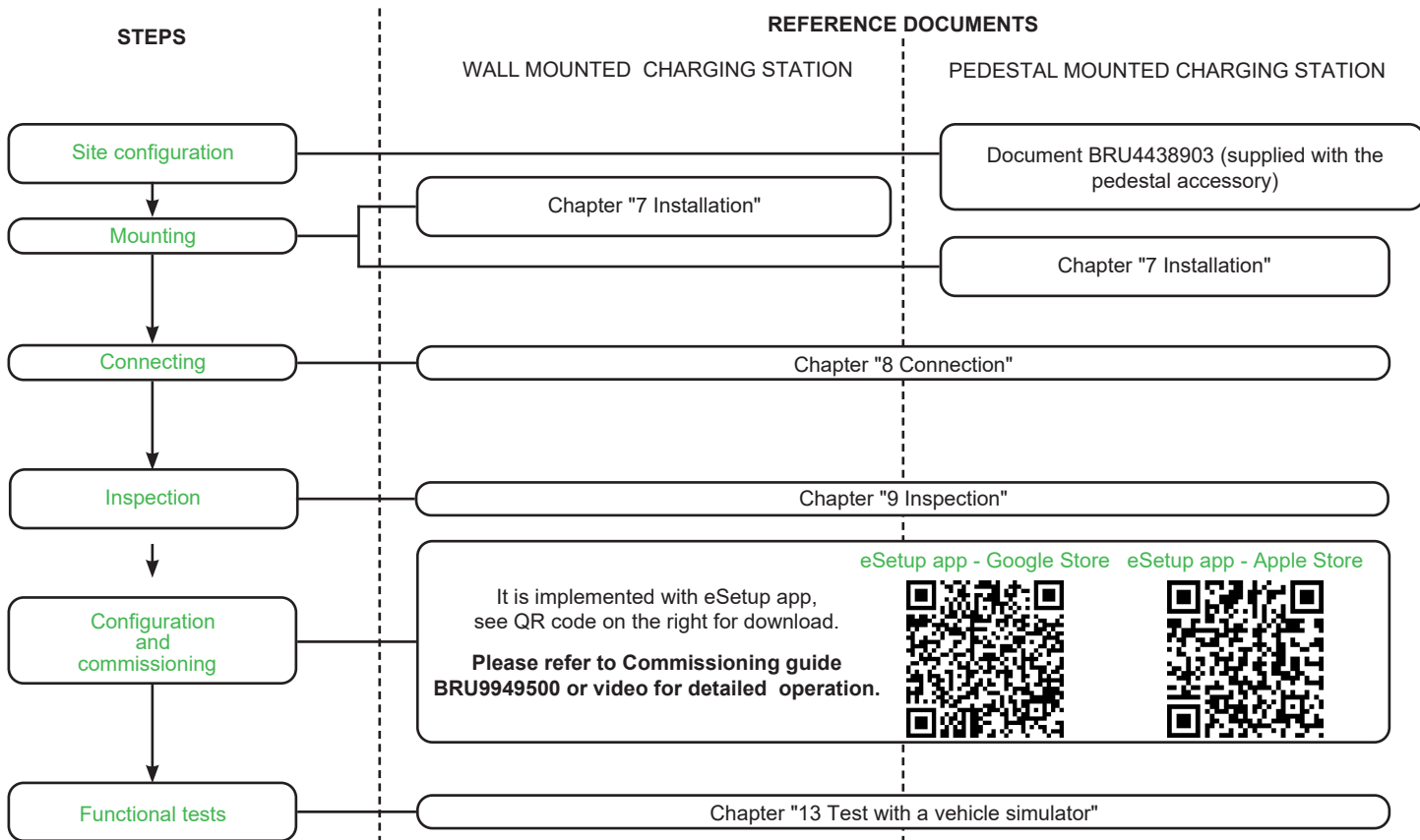

7 Installation

7.1 Equipment Supplied by User

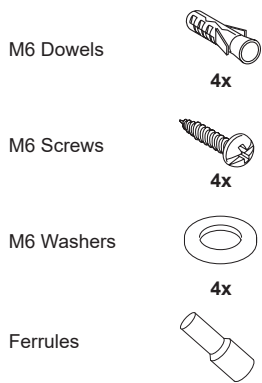

7.2 Tools Supplied by User

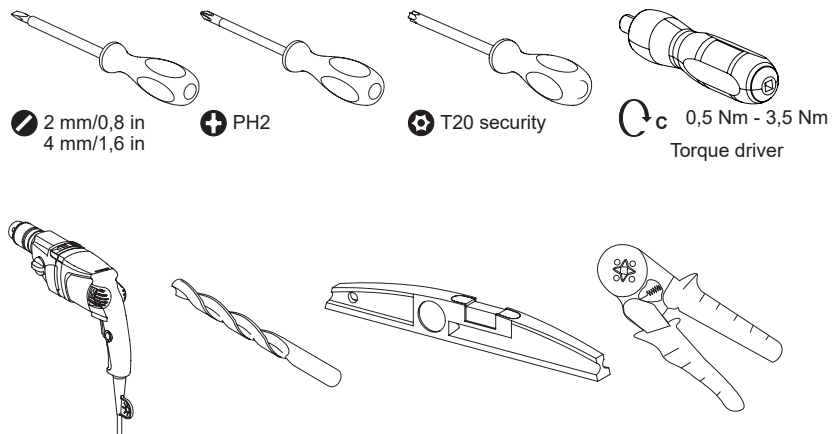

⚠️ ⚠️ DANGER

HAZARD OF ELECTRIC SHOCK, EXPLOSION OR ARC FLASH

Do not install the charging station in explosive environment.

Failure to follow these instructions will result in death or serious injury.

⚠️ WARNING

RISK OF DAMAGING THE CHARGING STATION

- Do not install the product under bad weather condition without adequate protections.
- Protect the charging station from dust and water while fixing the bracket.
- Attach the charging station to a flat surface.
- Use screws, washers and wall plugs suitable for the wall material.
- Screw head thickness should be less than 5.5 mm.

Failure to follow these instructions could result in death, serious injury, or equipment damage.

7.3 Wall Mounting

NOTICE

RISK OF UNSTABLE MOUNTING

- The wall must be vertical with a tolerance of no more than 5 mm.
- The fixing system (dowels) must be adapted to the wall and the weight of the product.
- Ensure there is enough space on right side of mounting position to operate side button and observe side LED.

Failure to follow these instructions could result in equipment damage.

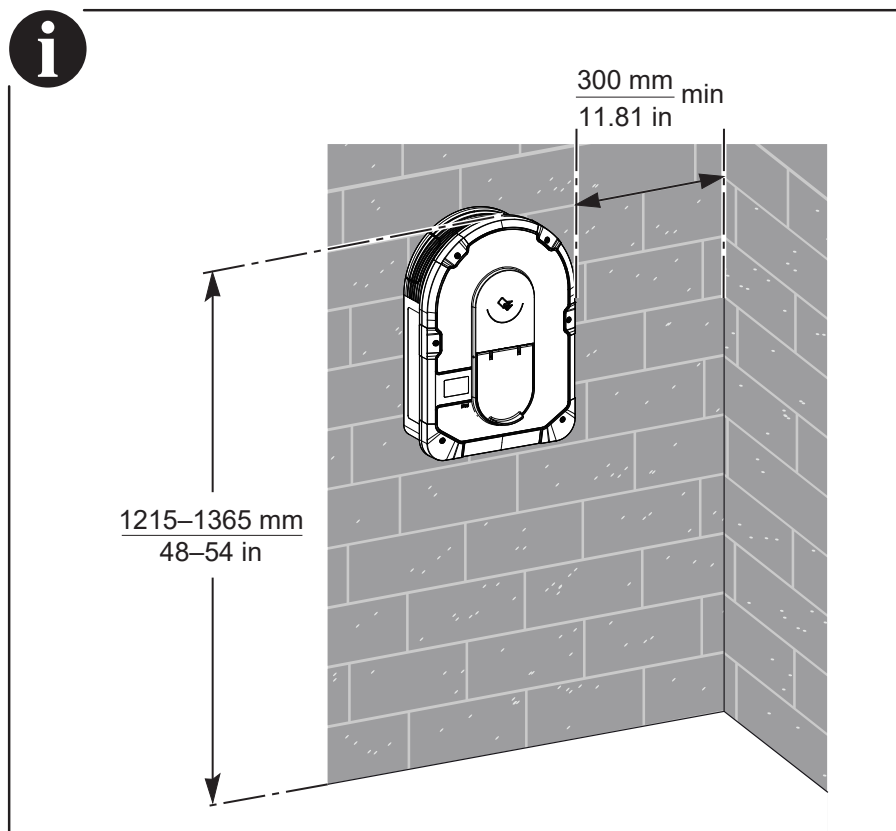

7 Installation

7.3 Wall Mounting

Cable entry from the bottom

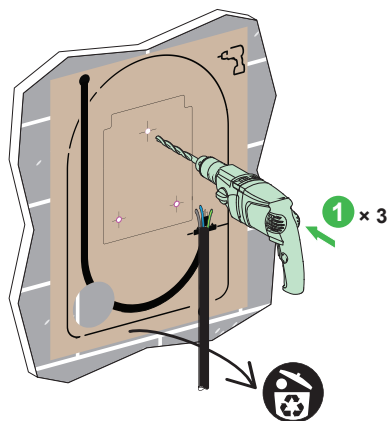

Cable entry through the wall

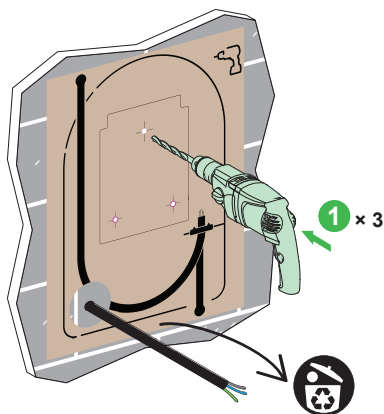

Cable entry from the top

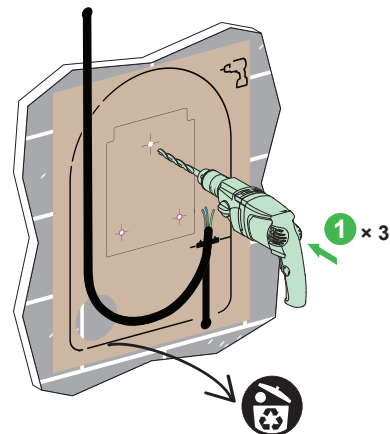

i Use spacers  if your wall is irregular.

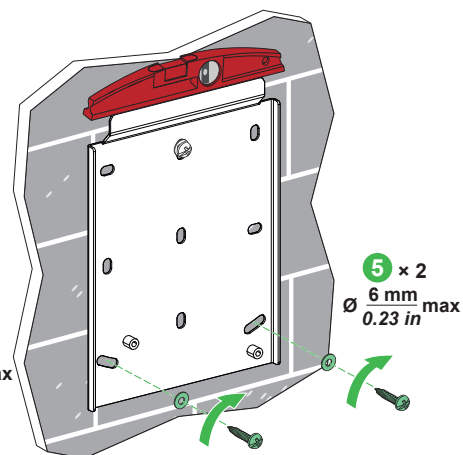
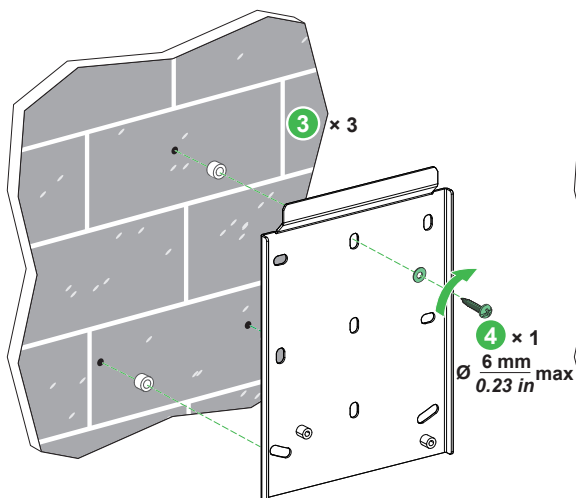
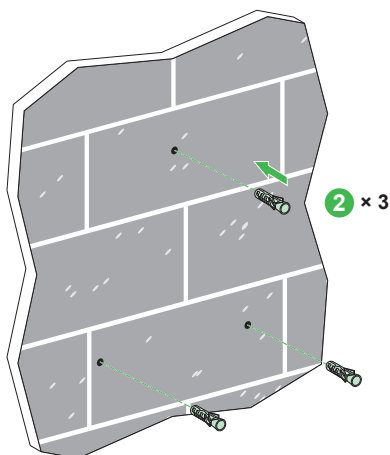

7 Installation

7.3 Wall Mounting

i If the power cable enters from the top, please open this knock-down hole.

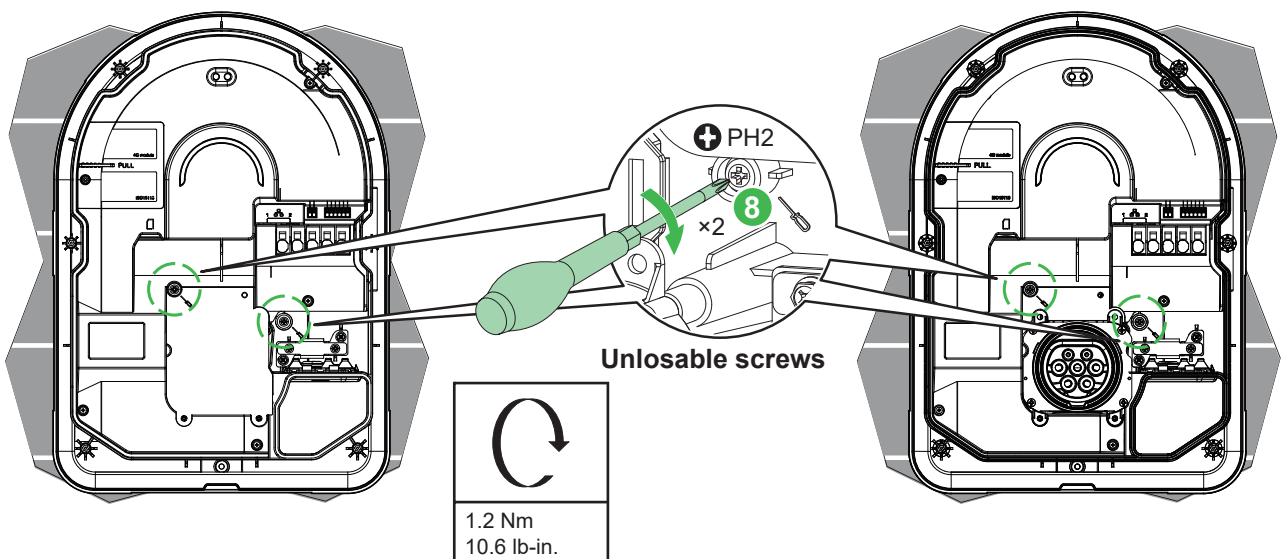
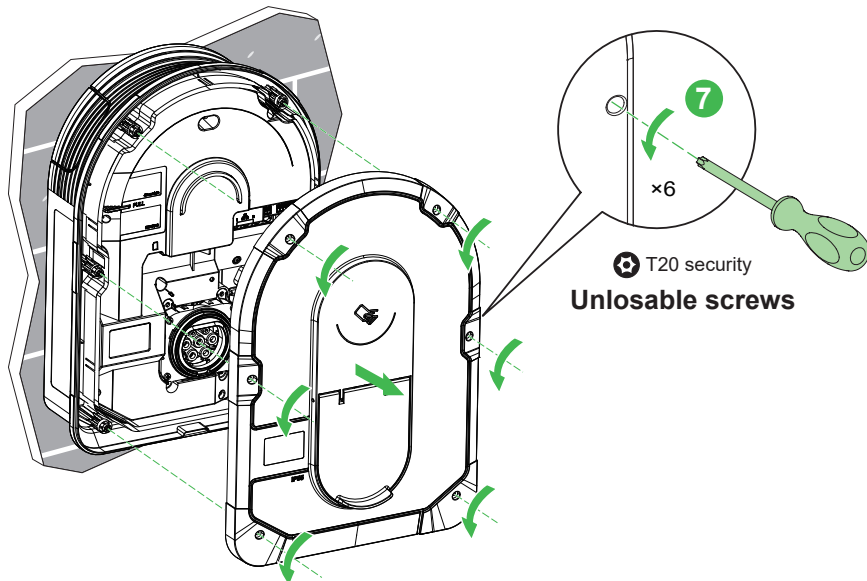
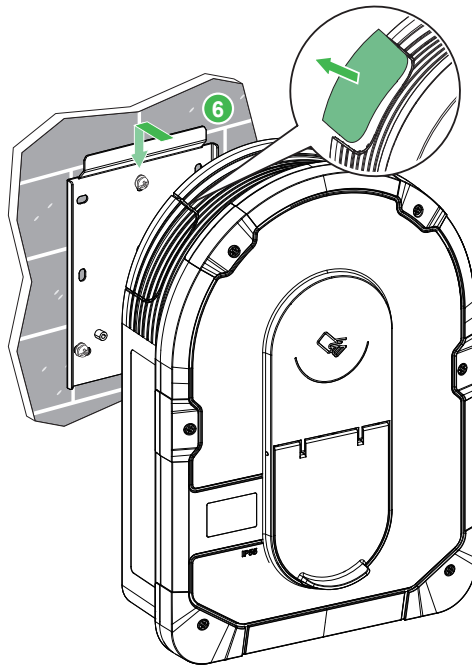

7 Installation

7.4 Wiring

- i** Remove the gasket from inside of the charging station and cut the hole size according to your cable diameter.

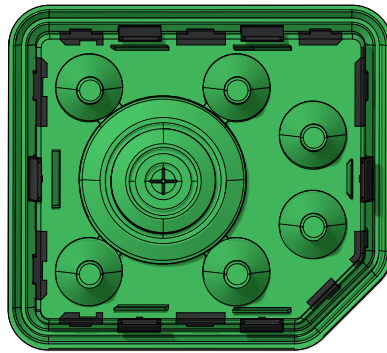

1 ↶

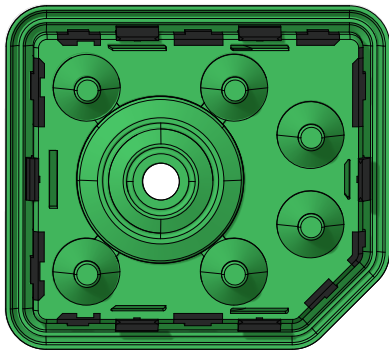

Φ10-15mm
0.4-0.6in

1 ↓

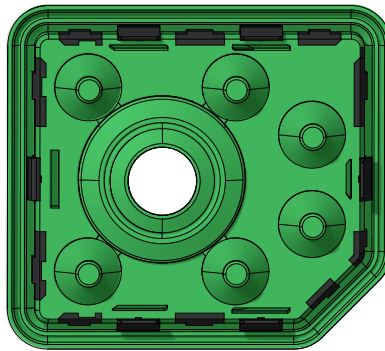

Φ15-20mm
0.6-0.8in

1 ↷

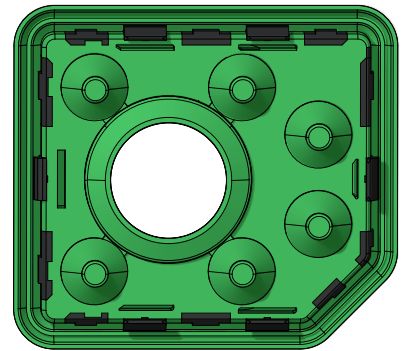

Φ20-23mm
0.8-0.9in

- i** Cut out the holes on gasket according to the number of signal cables in use.

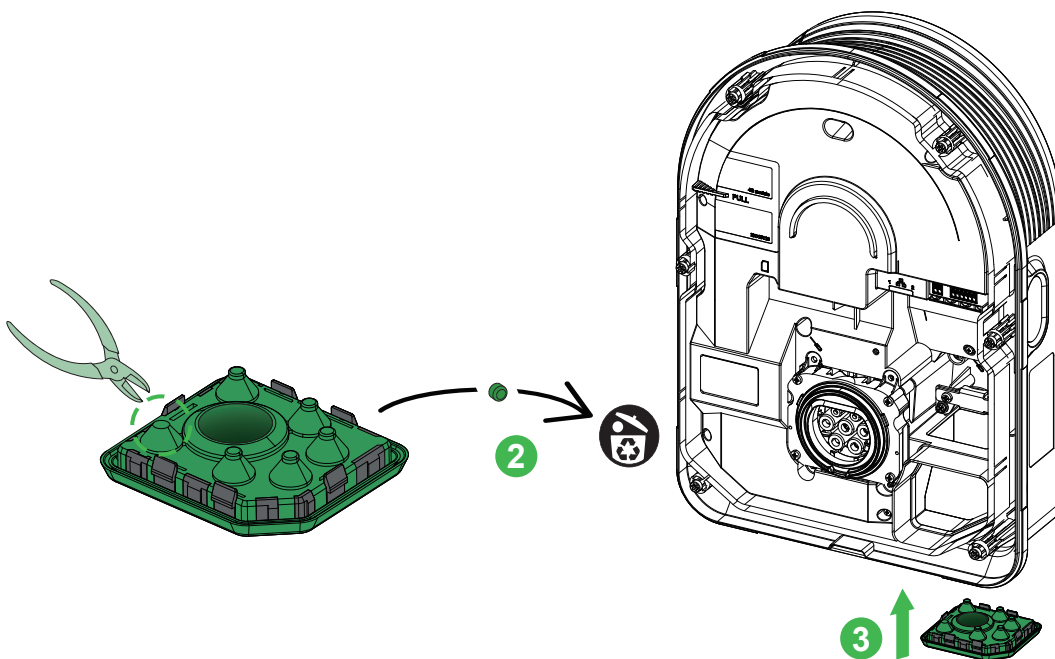

Routing of cables

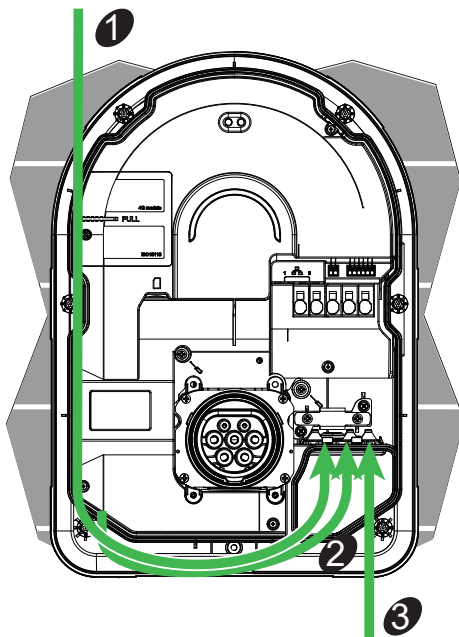

Three cabling scenarios

- ① Cable entry from the top
- ② Cable entry through the wall
- ③ Cable entry from the bottom



In the case of scenarios ① and ②, the possibility and routing are determined by the bending radius of the cable.

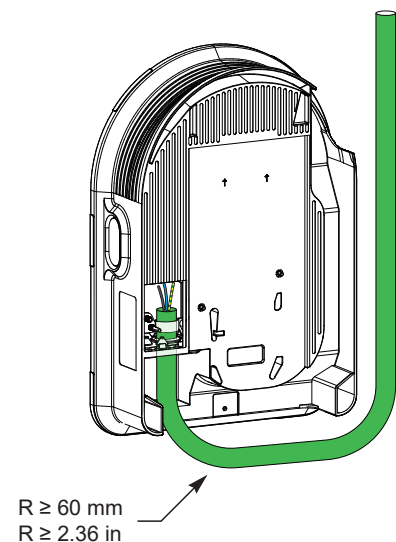
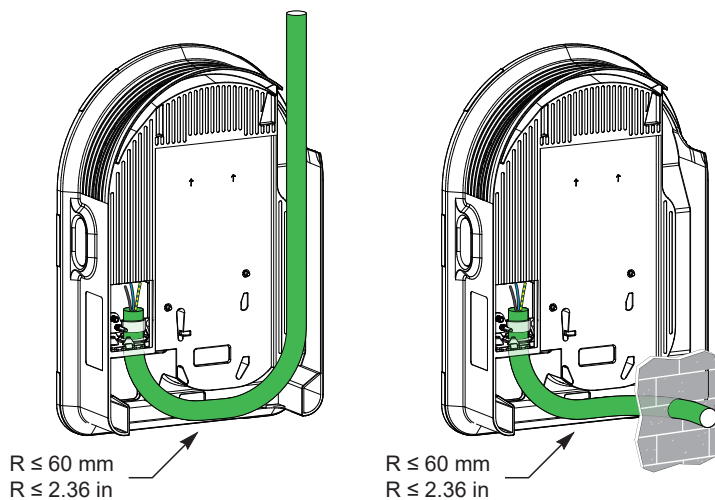
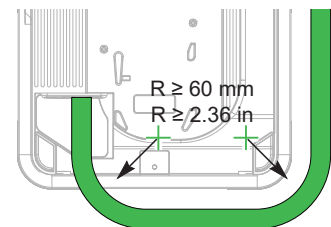
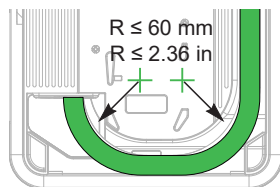

7 Installation

7.4 Wiring

Cable diameter: 10-20mm

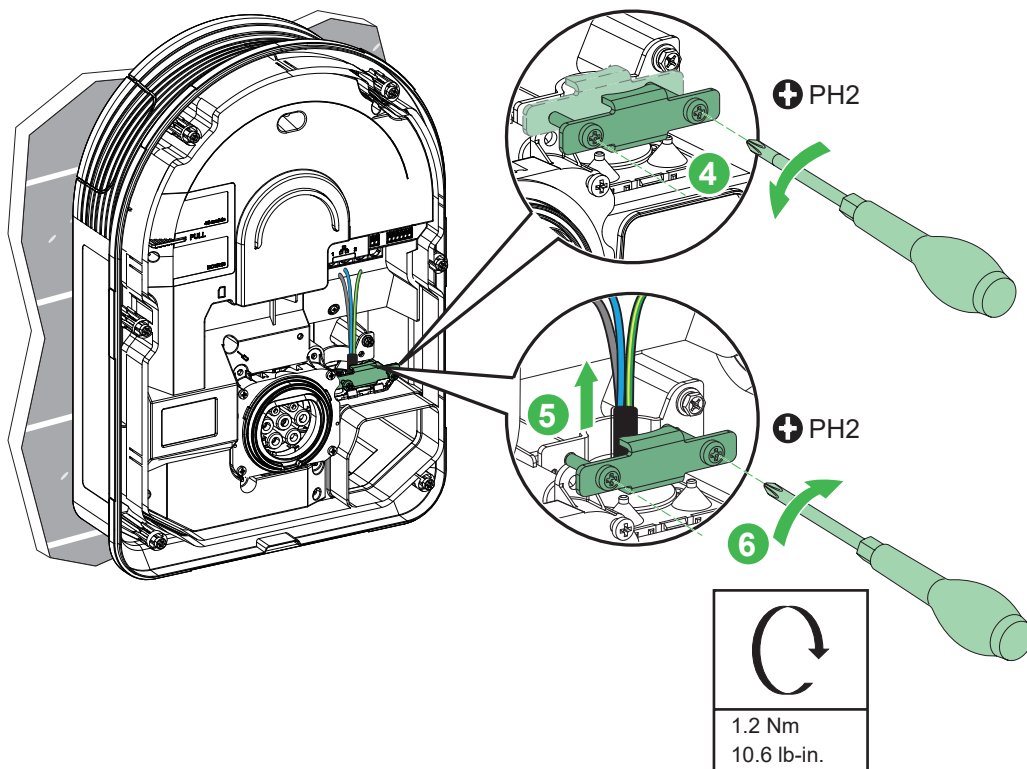

Cable diameter: 20-23mm

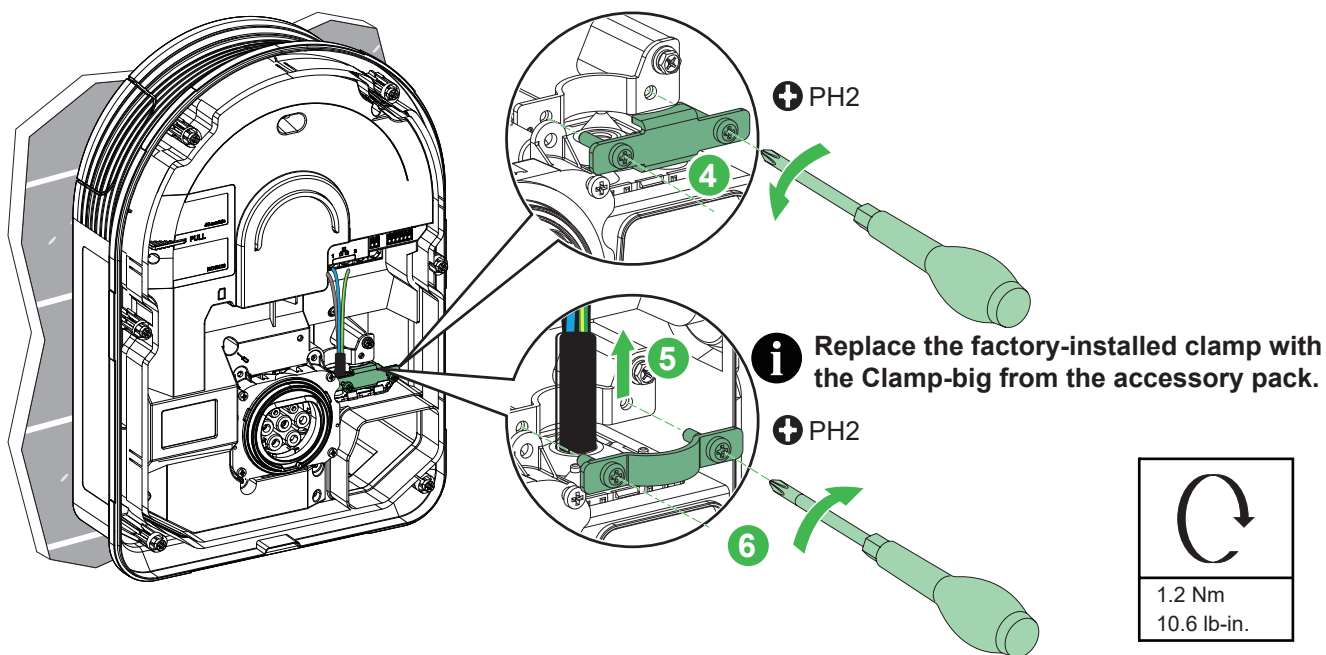

7 Installation

7.4 Wiring



Cable connection type	Cable section	
Flexible cable	2.5-10 mm ² AWG 13.2-7	19 mm 0.75 in
Rigid cable	2.5-10 mm ² AWG 13.2-7	19 mm 0.75 in

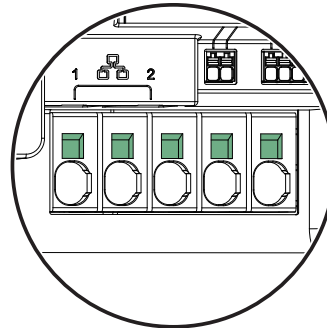
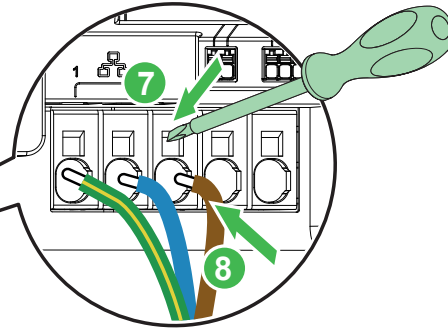
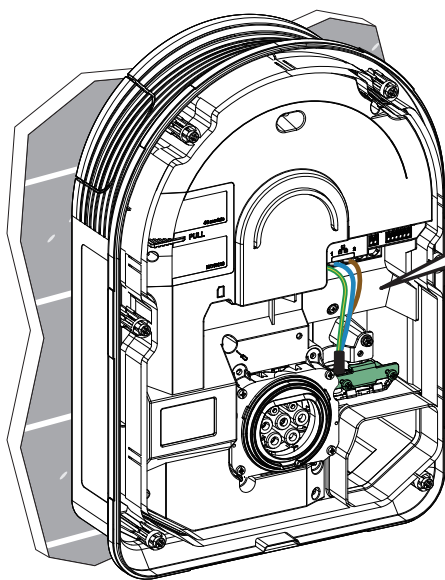

These position-windows could be used by Voltage absence tester (VAT).

NOTICE

INOPERABLE EQUIPMENT

- DSO terminals must only be connected to dry contacts without voltage.
- iMNx terminals from the charging station must only be connected to E1 E2 iMNx or MNx terminals, excluding any other tripping device.

Failure to follow these instructions could result in equipment damage.

7 Installation

7.4 Wiring

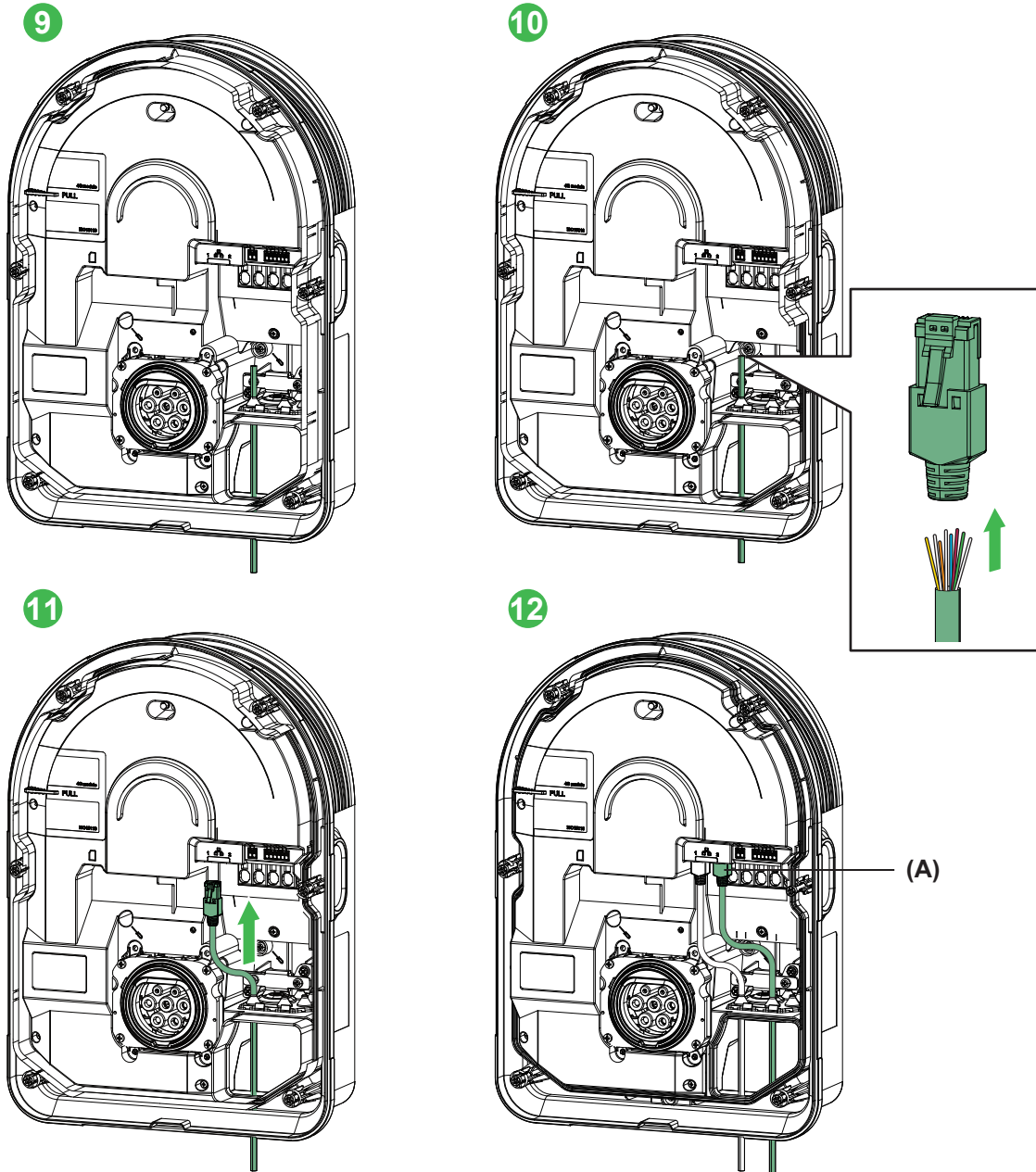

i A second connector (A) can be used for Ethernet daisy chain (up to ten charging stations in range).

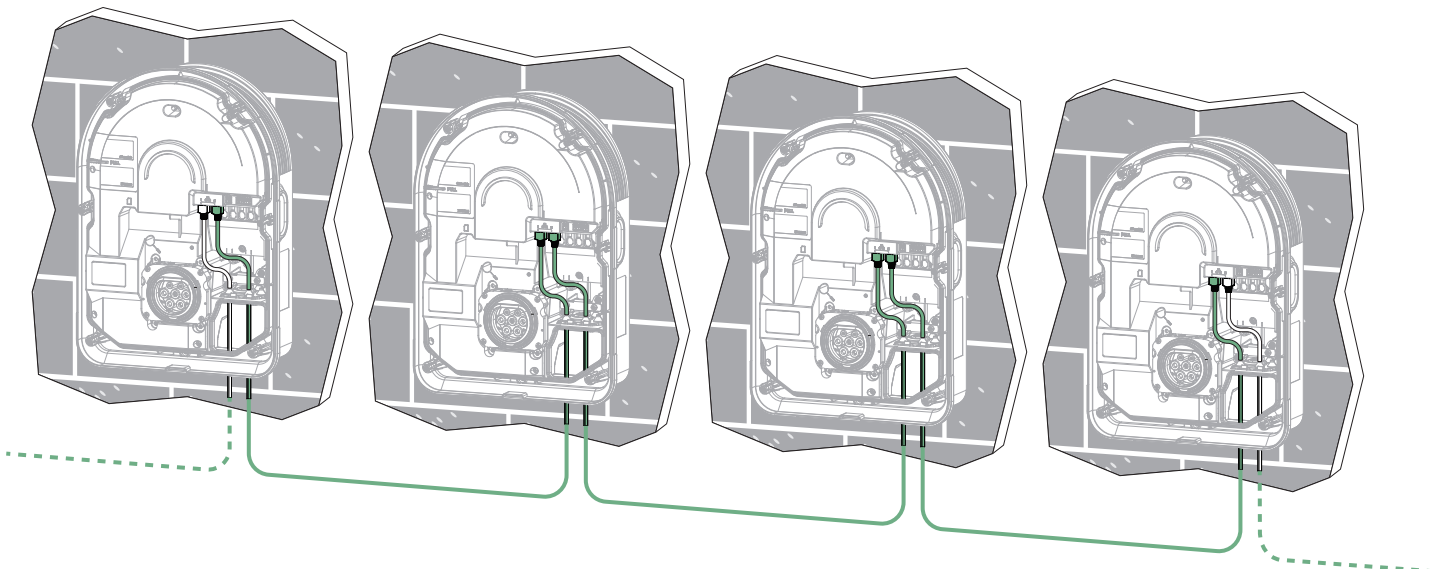

7 Installation

7.4 Wiring

iMNX/TIC/DSO wiring

i Skip step 13-15 if no use of iMNX/TIC/DSO/RS 485.

Cable section	
≤1.5 mm ² ≤AWG 15	9 mm ² 0.35 in

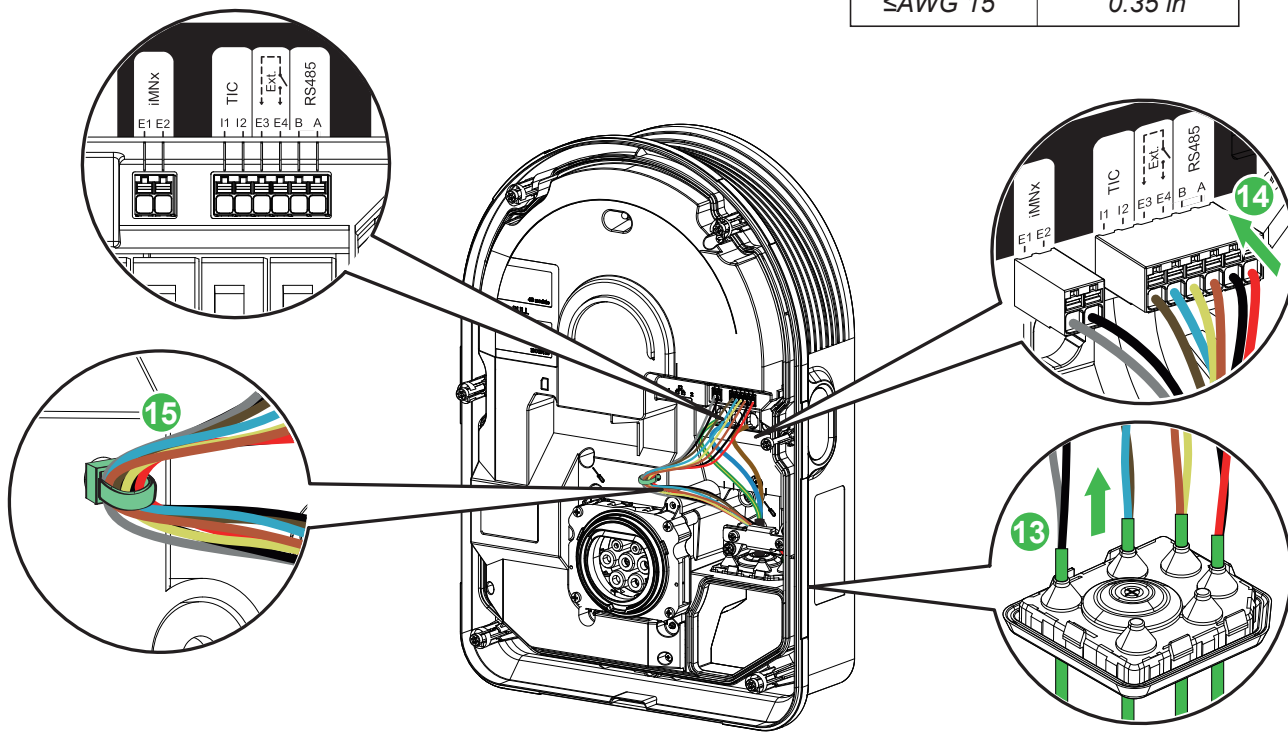

7.5 Cable Locker

i Cable locker is used to secure T2 cable, skip this part if no use of cable locker.

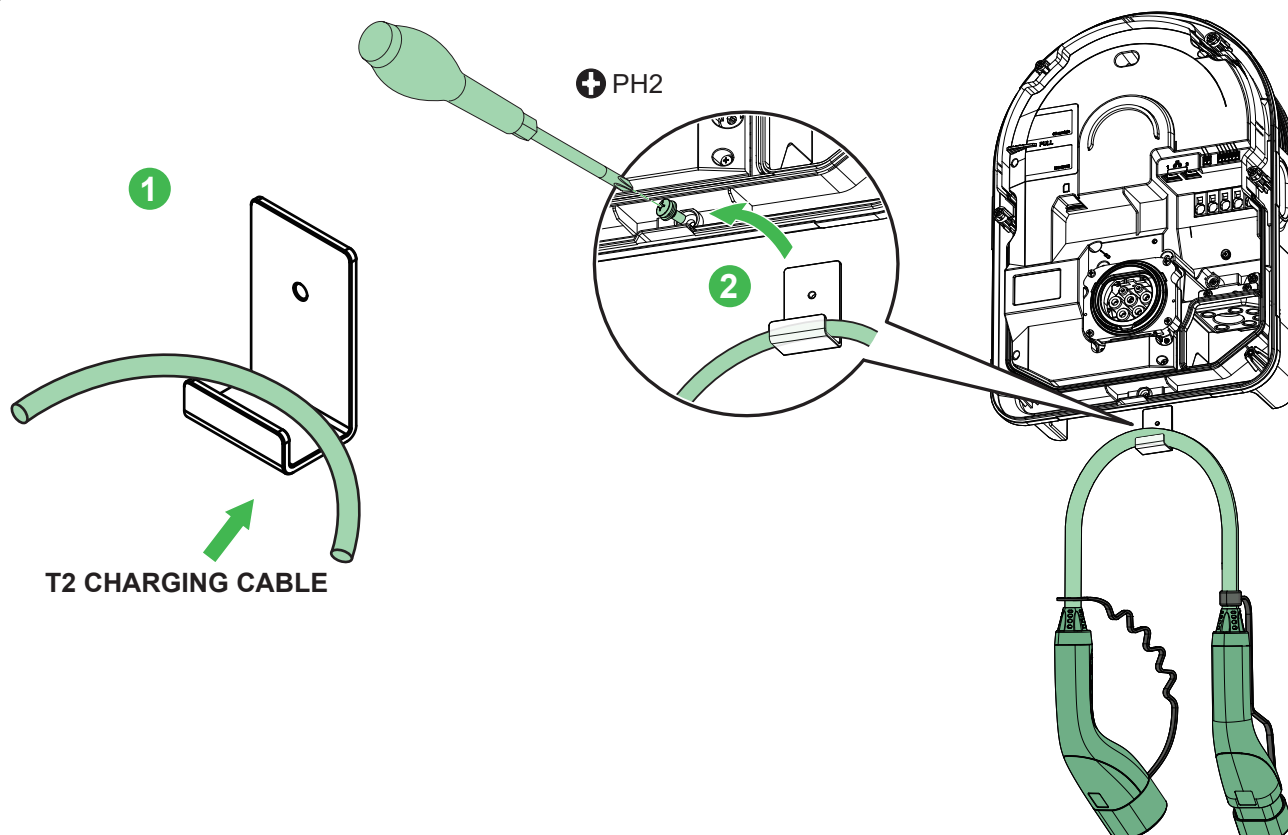

7 Installation

7.6 Mini SIM Card Insertion

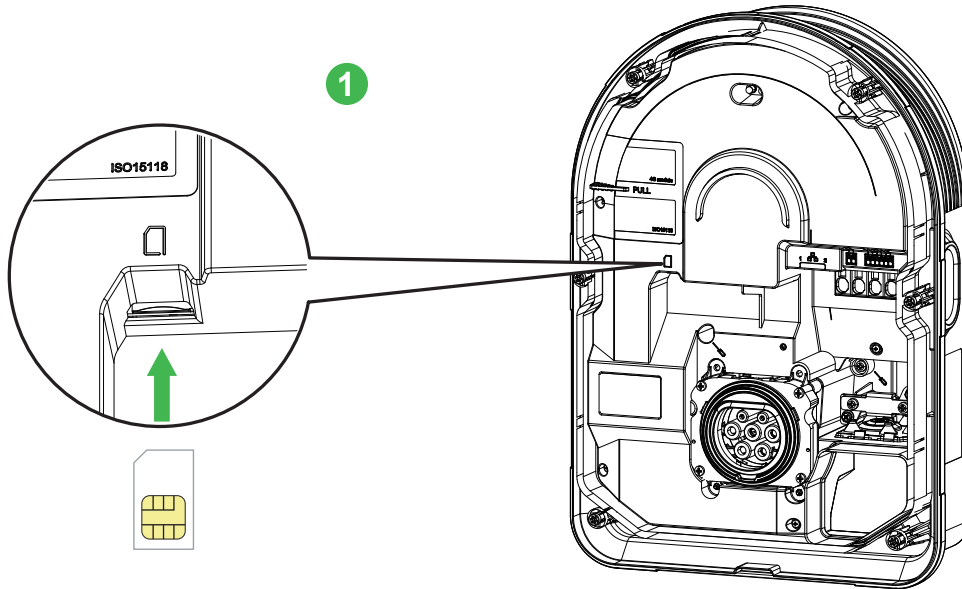

7.7 Installation Complete

i Select a safety label to install according to the required language.

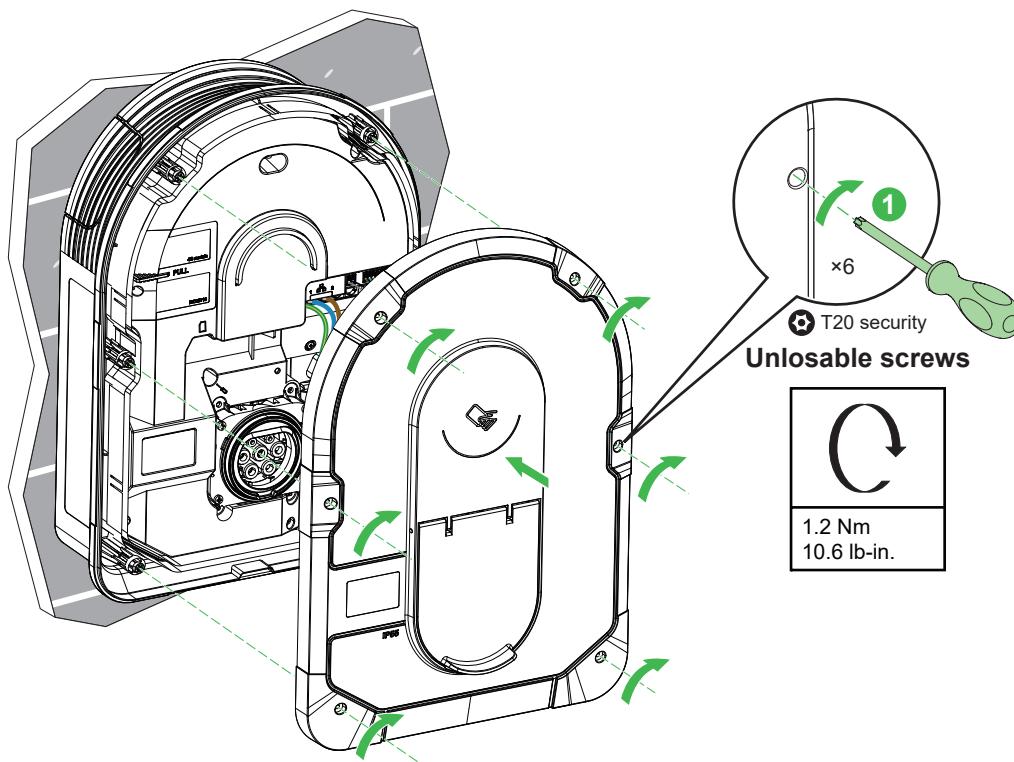

7 Installation

7.7 Installation Complete

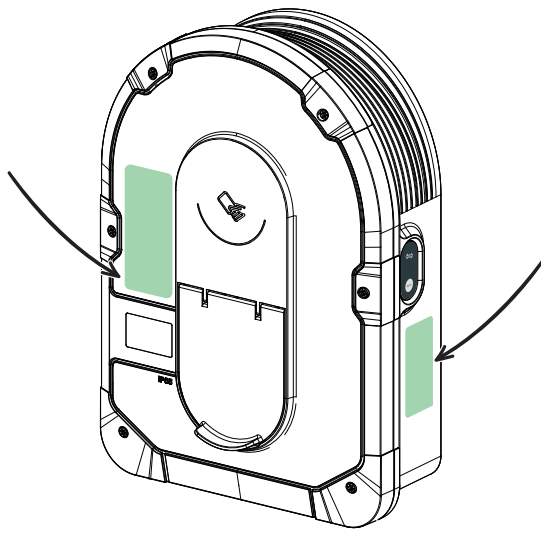

⚠️ ⚠️ DANGER

HAZARD OF ELECTRIC SHOCK, EXPLOSION OR ARC FLASH

- Return all devices, doors, and covers before turning on power to this device.
 - Beware of potential hazards, and carefully inspect the work area for tools and objects that may have been left inside the device.
- Failure to follow these instructions will result in death or serious injury.

8 Connection

8.1 Wire-up Signal Line

- i** TIC interface is only available for connection to French utility electronic meters. Please refer to section 11 for more details.
- i** RS485 interface is available for connection to external power meter (e.g. PowerTag Resi9). If the RS485 cable shield is grounded, please connect the earth wire to E4 on the left side.
- i** Both Eth1 and Eth2 can be used for Ethernet communication, if daisy chain is used please refer to section 7.4 for more details.

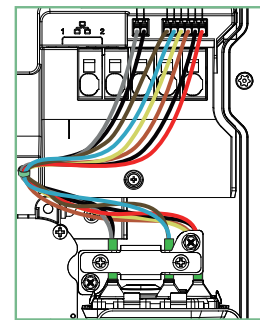
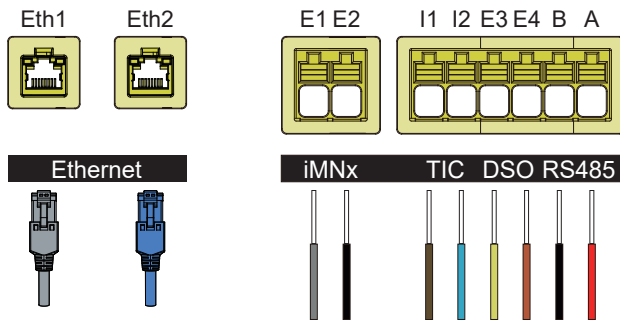

8.2 Wire-up Power Supply

TT/TN 1-Phase 220-240V

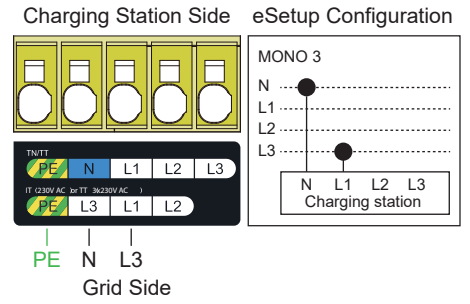
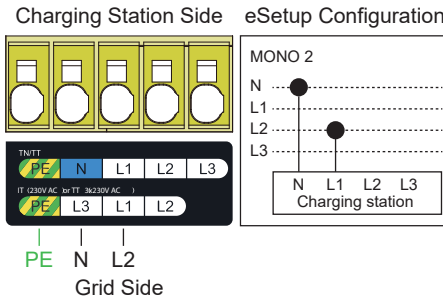
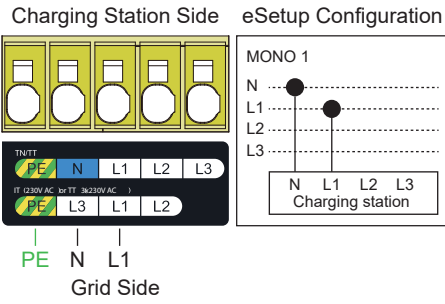

TT/TN 3-Phase 380-415V

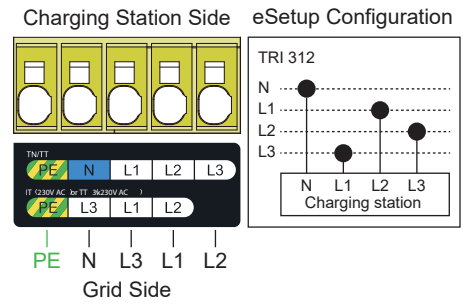
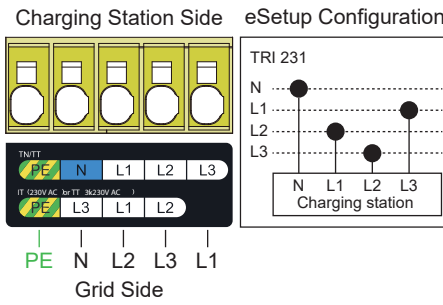
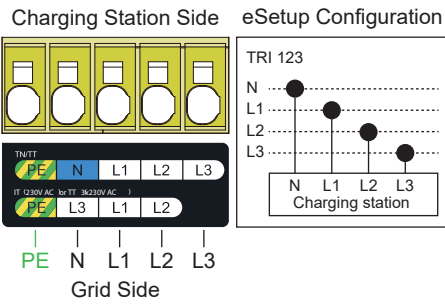

IT 1-Phase or TT without Neutral 220-240V

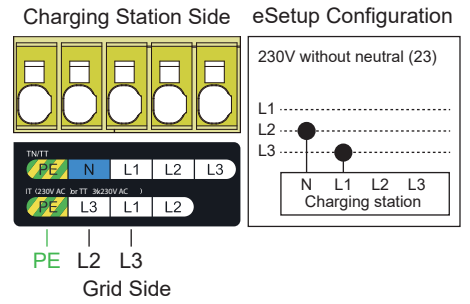
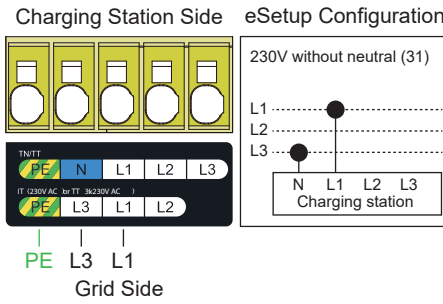
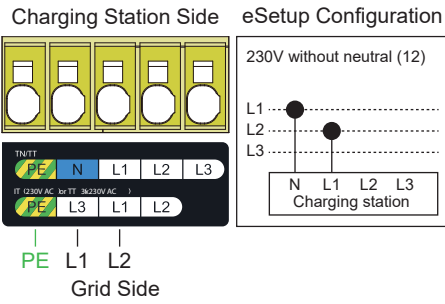

IT 3-Phase or TT without Neutral 220-240 V

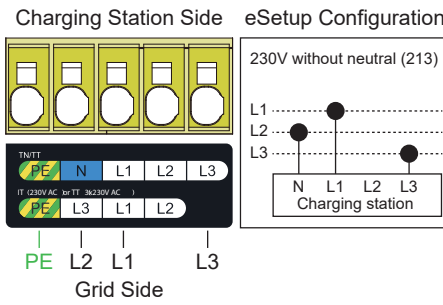
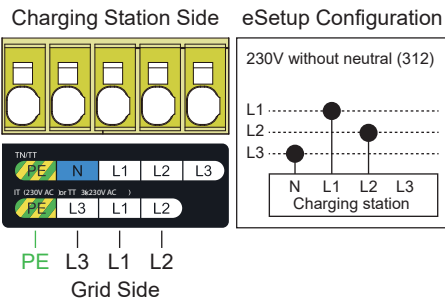

9 Inspection

⚠ ⚠ DANGER

HAZARD OF ELECTRIC SHOCK, EXPLOSION OR ARC FLASH

Wear suitable personal protective equipment (PPE) and follow all safety procedures.

Failure to follow these instructions will result in death or serious injury.

- Check that the inspection hatch is correctly screwed down.
- Ensure that the power cable is securely fastened by the crimping collar.
- Check that the cover of the charging station is intact and hasn't suffered any obvious mechanical damage or deformation.
- Check that the charging station is securely fastened to the wall.
- Check that nothing is impeding the connection of the charging cable to the charging station socket.

Note: If the maximum current of the charging station is reduced to less than 32A in the eSetup/ECCT application, this new current value must be visible on the charging station to comply with the NF C 15-100 standard.

10 Communication Feature

10.1 RFID

- NFC reader compatible with Class 1, Class 2, Class 3, Class 4, Class 5, Class 6 badges
- Badges compatible with the station's RFID badge reader:
 - Operating frequency bands: 13.56 MHz
 - ISO/IEC 14443 A 1-4 & B 1-4, ISO/IEC 15693 protocols
 - NXP Mifare Family
 - For other badges, please contact us.

10.2 Ethernet Port

Charging station has 2 Ethernet Ports:

- 10Mbps/100Mbps
- Auto detection of the speed
- Auto-MDI-X
- Functional Insulation
- A second connector can be used for Ethernet daisy chain, please see section 7.4 for more details.

10.3 Modbus RTU

Charging station has a Modbus RTU interface to connect an external Smart Meter:

- Charging station shall be the MASTER station.
- Charging station could autodetect the speed of communication.
- Maximum Distance = 200m
- 19200 bps, 8 bits data, 1 bit stop, Even polarity

10.4 GSM, UMTS and LTE Network Interface

The charging station implements GSM (2G), UMTS (3G) and LTE (4G) network interface to choose among:

- GSM B2/3/5/8
- WCDMA B1/2/4/5/6/8/19
- LTE-FDD B1/2/3/4/5/7/8/12/13/18/19/20/25/26/28/66
- LTE-TDD B34/38/39/40/41

11 Energy Management (For Charge Pro with TIC Function)

- The charging station is fitted with a TIC input (Tele-Information Consumer) enabling it to be connected to French utility electronic meters (former electronic meters and new Linky meters).
- The TIC link is to be wired to the terminal block I1-I2.
- The TIC interface is intended to limit the power consumed by the car when the power requested is greater than the power available in the installation (utility meter or connection circuit-breaker) when the overall consumption of the home is close to the subscribed power. The TIC interface serves to avoid the tripping of the main circuit breaker when the overall electrical consumption of the home is close to the subscribed power. In some cases, the TIC interface can completely stop the EV charging, to avoid a power outage of your home electrical supply.
- Only one charging station can be interfaced with the meter. No manual setting is needed. As per the information provided by the TIC interface - instant overall current and subscribed current value - the charging station calculates the maximum charging current value available for the electric vehicle and automatically adjusts the maximum charging current setpoint value given to the vehicle. When the value gets lower than the minimum acceptable by the vehicle the charging process is suspended and will resume as soon as possible.
- It is recommended to use Anti-Tripping Module if TIC is not available.

12 External Power Meter

12.1 PowerTag Energy Resi9

- The Energy sensor, PowerTag Energy Resi9 measures current, voltage, energy consumption, etc. for monitoring. This energy sensor provides bi-directional active energy. The active energy is saved in the non-volatile memory of the energy sensor. The energy sensor provides highly accurate measurement and average value. To be completed with Resi9 Current Transformer 80A.
- The function of R9M80X6M or R9MUX6M with Schneider Charge Pro is to implement load management. To enable this feature, you need to conduct commissioning through eSetup Application. For more demands and details in use, please refer to the Modbus Connectivity Guide NAT3046700.

12 External Power Meter

12.2 P1 Smart Meter and P1MB Gateway

- P1MB is a device which interfaces to the P1 port of a P1 smart meter and transforms the data and make it available on its Modbus slave interface to be read out via a Modbus RTU by Schneider Charge Pro.
- The function of P1 smart meter + P1MB gateway + Charge Pro is to implement load management, which is mainly used in Belgian or Dutch market. To enable this feature, you need to conduct commissioning through eSetup Application. For more demands and details in use, please refer to the Modbus Connectivity Guide NAT3046700.

13 Operation

▲ CAUTION

RISK OF INJURY

Do not use any extension cable or adaptor to connect the charging station to the electric vehicle.
Failure to follow these instructions could result in injury, or equipment damage.

13.1 Connecting the Electric Vehicle Charging Station

- Connect the charging cable's plug into the Electric Vehicle charging station's socket.
- Connect the charging cable's connector into the Electric Vehicle's inlet.
- The charging station's LED indicator will change from a solid green to pulsing blue.
- If the charging station set to the authorisation mode, please swipe the card within 3 cm to activate it.
- The charging station's built-in MID meter screen scrolly displays data such as current, voltage, power and kWh, which could be viewed through the visual window.

13.2 Disconnecting the Electric Vehicle

▲ WARNING

RISK OF INJURY

Do not use brute force to unplug the charging connector from the Electric Vehicle as it is mechanically locked.
Failure to follow these instructions could result in death, serious injury, or equipment damage.

- Stop the charging session via the Electric Vehicle to unlock the connector.
- Unplug the charging station's connector from the Electric Vehicle's inlet.
- Wind the charging cable around the Electric Vehicle charging station's winding trough.

14 Test with a Vehicle Simulator

- In the absence of an available electric vehicle, check that the charging station is functioning correctly with a vehicle simulator.

⚠ ⚠ DANGER

HAZARD OF ELECTRIC SHOCK, EXPLOSION OR ARC FLASH

Regularly check the integrity of the cable.

Failure to follow these instructions will result in death or serious injury.

- Ensure that the charging connector and charging cable are securely stored between charging sessions.
- Wrap the charging cable around the charging station's cable trough.
- If the Schneider Charge Pro is installed outdoors, remove the cap in order to prevent water entering the connector.
- If the Schneider Charge Pro is installed indoors, protect the connector by covering it with the dust cap.
- It is recommended to use Schneider Charge cable Holder (EVA5GH) to hold the connector during non-charging sessions.

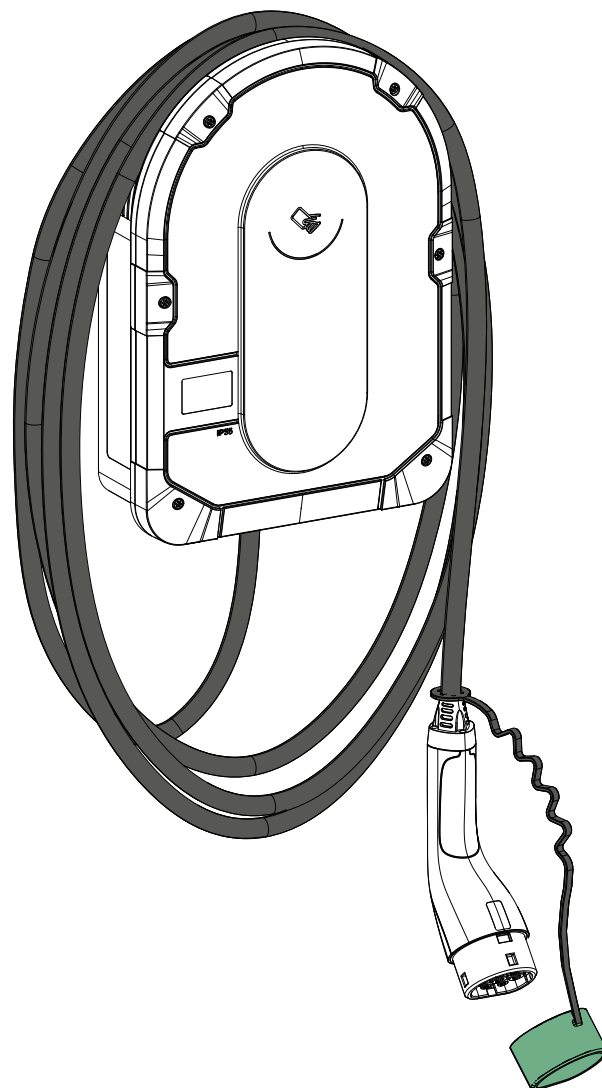
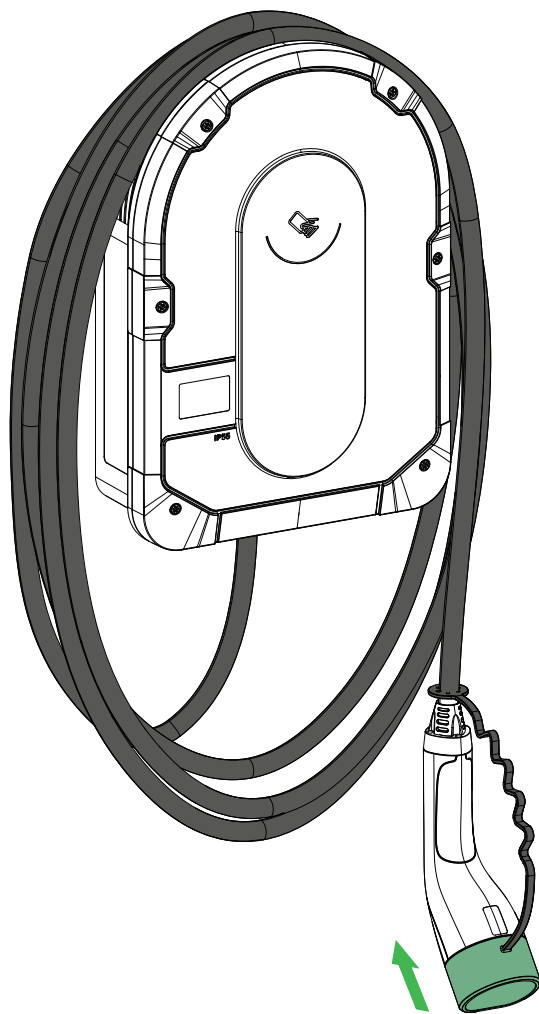

16 Reset to Factory

⚠️ ⚠️ DANGER

HAZARD OF ELECTRIC SHOCK, EXPLOSION OR ARC FLASH

Do not perform "Reset to Factory" during a firmware update or while a charging process.
Failure to follow these instructions will result in death or serious injury.

16.1 Operation by eSetup Application

- Reset to factory allows you to return all settings of the charging station to its initial state. Two actions are needed to launch it.
 - Set your charging station in commissioning status and connect it to the eSetup application on your smartphone, please refer to the Schneider Charge Pro commissioning guide BRU9949500 for more details of this operation.
 - On eSetup application, go to the main page and click on the settings menu (top right gear menu). A click on "Reset the configuration" and confirmation of this action to launch the reset.

The image shows three sequential screenshots of the Schneider Charge Pro mobile application.
1. The first screenshot shows the main settings page with a gear icon in the top right corner. A hand icon points to this gear icon, labeled with a blue circle '1'.
2. The second screenshot shows a context menu that appears after tapping the gear icon. The menu options are 'Identify the charger', 'Restart the charger', and 'Reset the configuration'. A hand icon points to the 'Reset the configuration' option, labeled with a blue circle '2'.
3. The third screenshot shows a confirmation dialog box titled 'Reset the configuration'. The text inside reads: 'Factory reset removes all settings from the charger. You will have to wait for about 5 minutes. If you confirm it, you will be disconnected.' At the bottom of the dialog are 'Cancel' and 'Continue' buttons. A hand icon points to the 'Continue' button, labeled with a blue circle '3'.
At the bottom of each screenshot is a green 'Continue' button.

16.2 Operation by Dip Switch

⚠️ ⚠️ DANGER

HAZARD OF ELECTRIC SHOCK, EXPLOSION OR ARC FLASH

- Be aware of potential hazards, and carefully inspect the work area for tools and objects that may have been left inside the device.
 - Wear suitable personal protective equipment (PPE).
 - Do not operate under bad weather condition without adequate protections.
- Failure to follow these instructions will result in death or serious injury.

NOTICE

RISK OF DAMAGING THE CHARGING STATION

- Do not touch the electronic boards by hand or with a tool (e.g. screwdriver).
 - Make sure that all signal cables and antennas are not covered or pinched, especially for cables of side button.
- Failure to follow these instructions could result in equipment damage.

- When eSetup application is not available or when the operation fails via eSetup application, the function can be performed via the internal dip switch of the charging station as below.
 - Power off the charging station. Then open the front cover and PCBA cover and turn the second left dip switch (SW4) to the ON position. Reinstall the PCBA cover and front cover.
 - Power on the charging station. Wait about 2 minutes until the side LED turns green.
 - Power off the charging station again. Then open the front cover and PCBA cover and turn the second left dip switch (SW4) to the initial position. Reinstall the PCBA cover and front cover again.
 - Power on the charging station again. Wait about 2 minutes, if the charging station could reboot automatically means the reset is successful.

16 Reset to Factory

16.2 Operation by Dip Switch

i Step 1-2: Power off the charging station, then open the front cover.

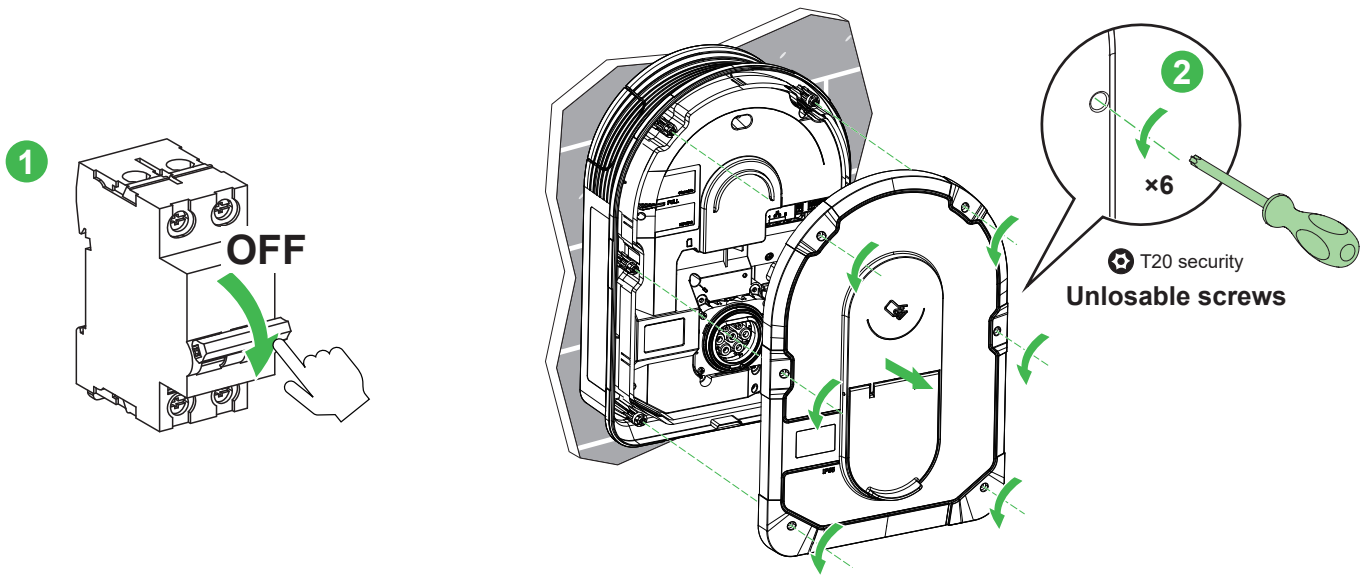

i Step 3-4: Open the PCBA cover and turn the second left dip switch (SW4) to the ON position.

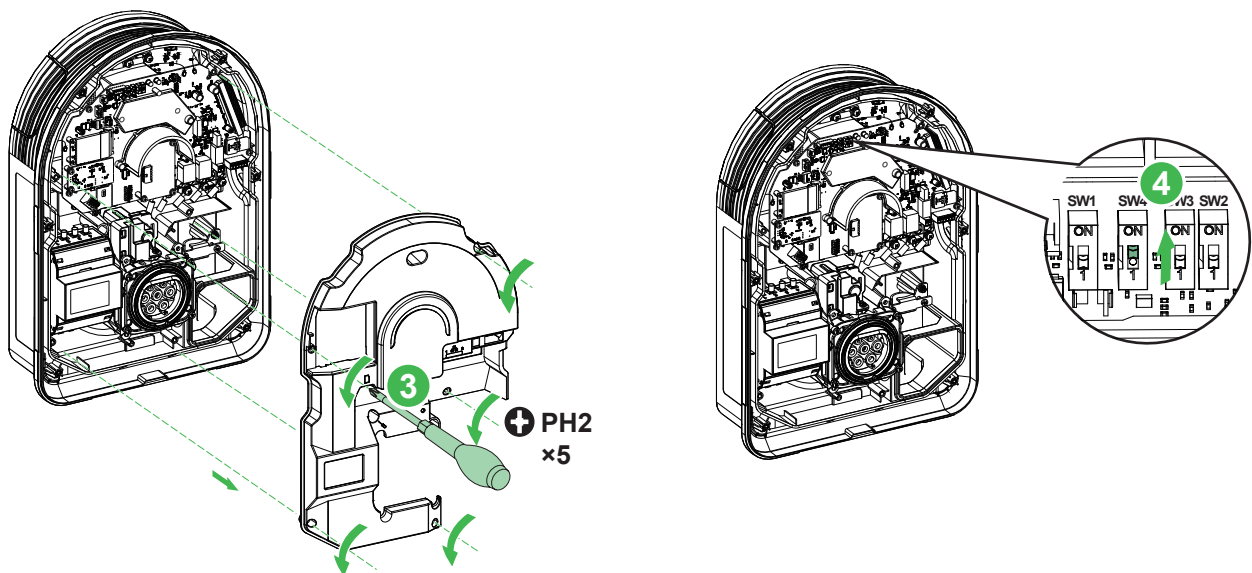

i Step 5-6: Reinstall the PCBA cover and front cover.

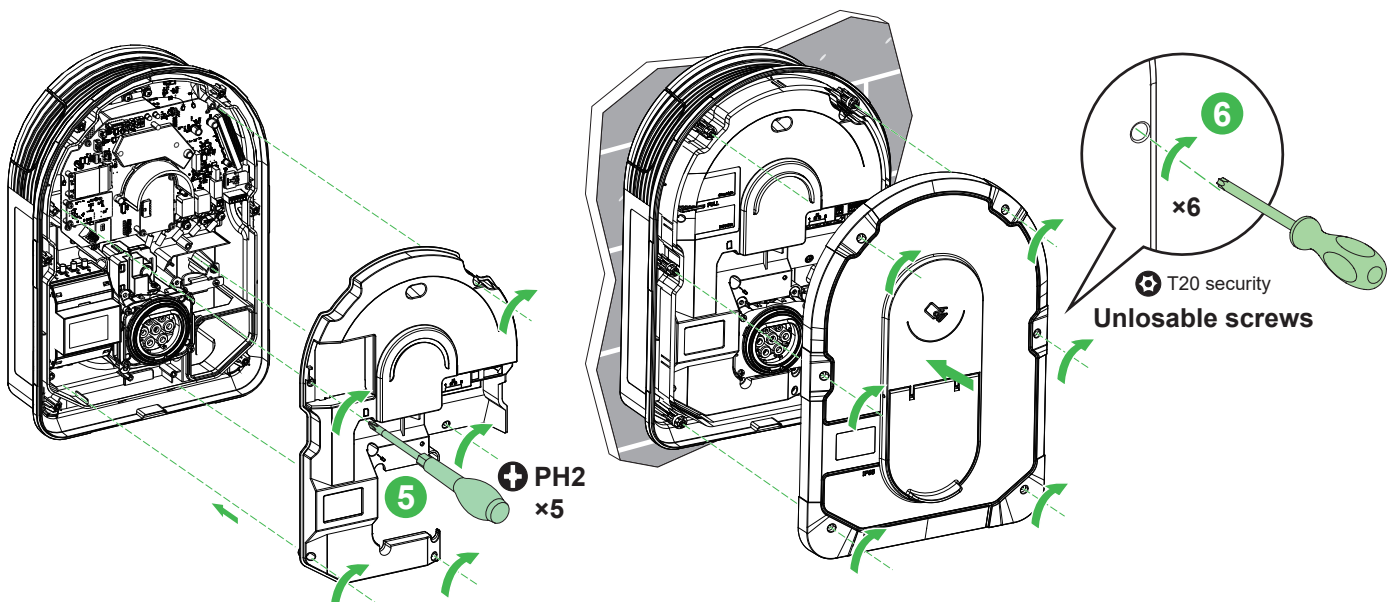

16 Reset to Factory

16.2 Operation by Dip Switch

i Step 7-8: Power on the charging station. Wait about 2 minutes until the side LED turns green.



i Step 9-10: Power off the charging station again, then open the front cover.

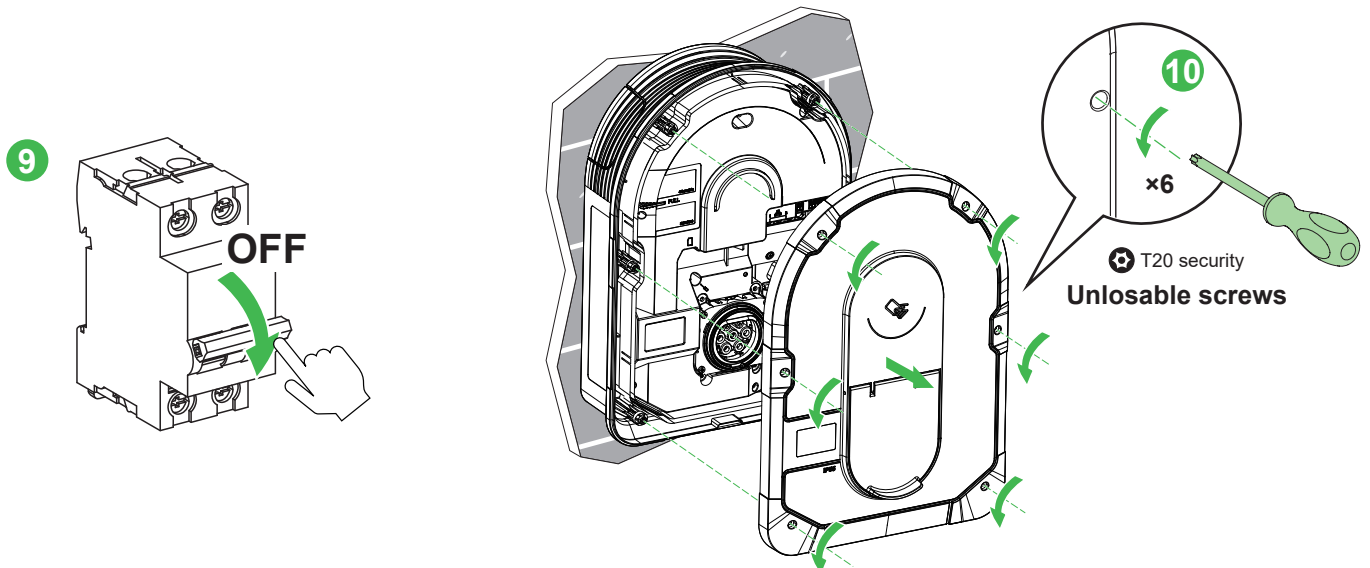

i Step 11-12: Open the front cover and PCBA cover and turn the second left dip switch (SW4) to the initial position.

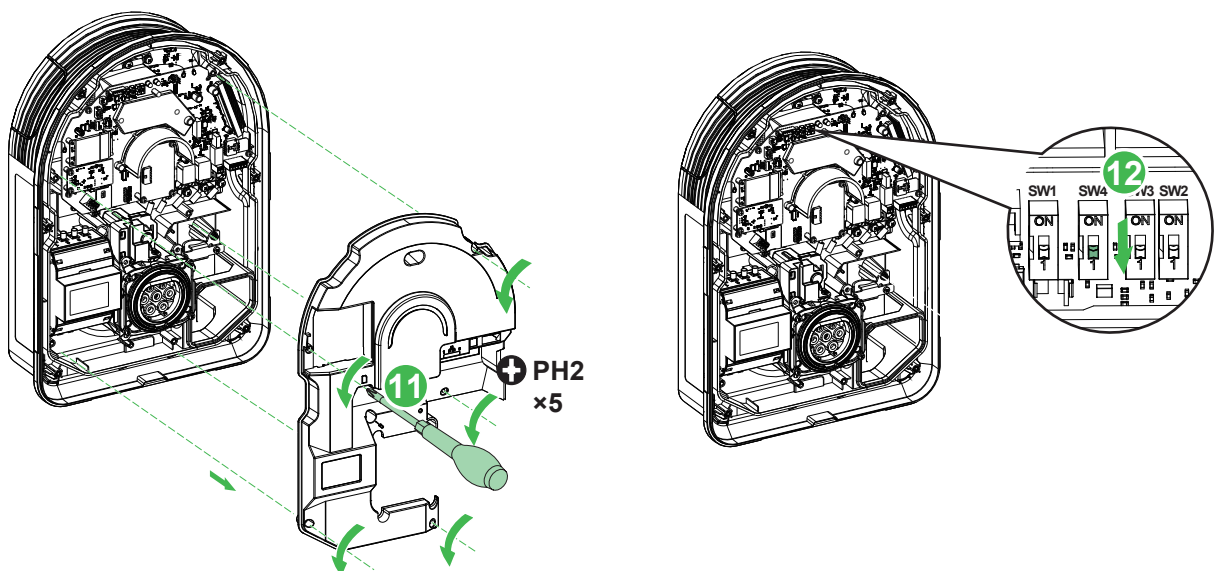

16 Reset to Factory

16.2 Operation by Dip Switch

i Step 13-14: Reinstall the PCBA cover and front cover again.

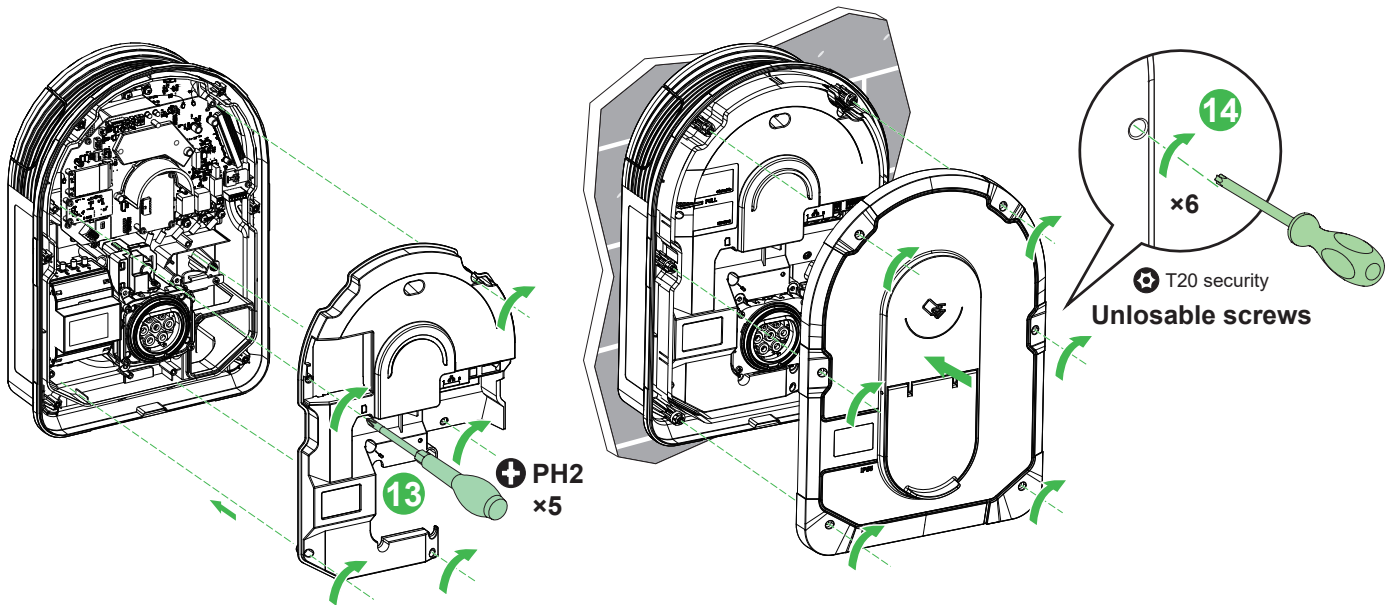







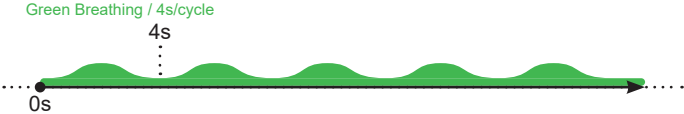

i Step 15-16: Power on the charging station again. Wait about 2 minutes, if the charging station could reboot automatically means the reset is successful.

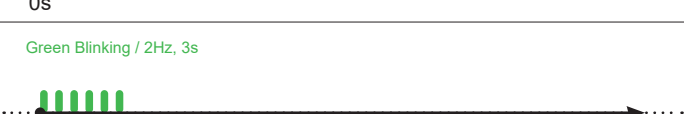

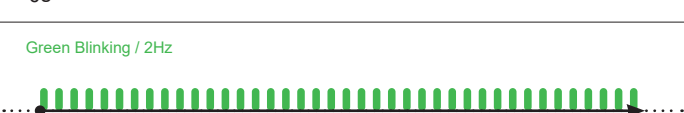
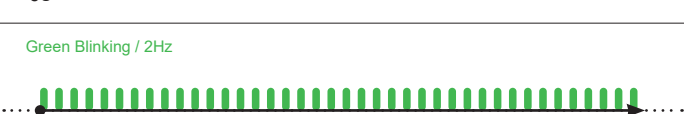
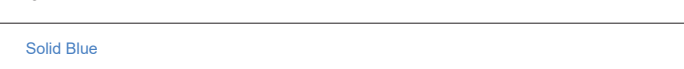
17 Charging Station Indicators

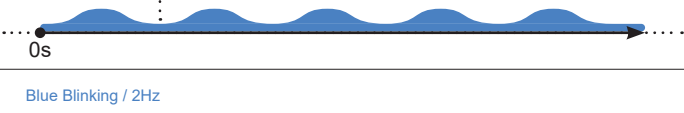
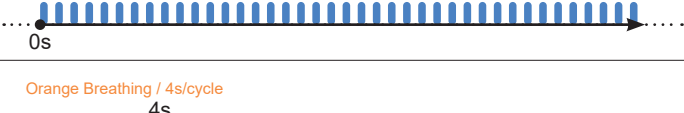
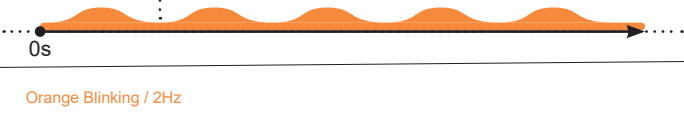
17.1 Front LED Color

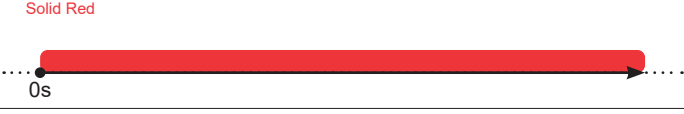
Charging station status by Front LED		Type of light
		
Wi-Fi AP activated	Wi-Fi access point activated	<p>Green Breathing / 4s/cycle</p> 
Charge point status	Available	<p>Solid Green</p> 
	Locked or reserved	<p>Solid Orange</p> 
Communication setup status	Localization request	<p>Green Blinking / 2Hz, 3s</p> 
	A badge or authentication asking is detected.	<p>Green Blinking / 1Hz, 1s</p> 
	Firmware upgrade in process	<p>Green Blinking / 2Hz</p> 
Charging status	Authentication in progress OR waiting for EV connection after badge authorized	<p>Green Blinking / 2Hz</p> 
	Charge in preparation (after badge authorized and EV connection) OR Charge suspended by EV OR Finishing (charge stopped by RFID or remotely and EV still connected)	<p>Solid Blue</p> 
	EV plugged and in charge	<p>Blue Breathing / 4s/cycle</p> 
	Charge suspended by EVSE OR by the smart charging application OR by lack of remaining power in the house	<p>Blue Blinking / 2Hz</p> 
Error	Connection failure to new platformer in supervision model during the commissioning process	<p>Orange Breathing / 4s/cycle</p> 
	eSetup pairing failure (5s) OR Authentication failure (2s)	<p>Orange Blinking / 2Hz</p> 
	All errors except RDC-DD Tripping: Electrical safety error, Internal error, EV communication, Power Meter communication, OCPP communication	<p>Solid Red</p> 
	DC leakage value higher than 6mA	<p>Permanent Red Blinking / 2Hz</p> 

17 Charging Station Indicators

17.2 Side LED Color

Charging station status by Side LED		Type of light
Wi-Fi Status	Wi-Fi AP mode Available	<p>Solid Green</p> <p>Duration : 30 min max</p>
	Wi-Fi AP mode activated	<p>Blinking Green / 1,5Hz</p> <p>Duration : 30 min max</p>
Anti-tripping module status	Anti-tripping module unpaired and pairing activated	<p>Blinking Blue / 1,5Hz</p> <p>Duration for pairing unsuccessed : 10 min max Duration for pairing successed : 0s max</p>
	Anti-tripping module unpairing succeed	<p>Fast Blinking Blue / 4Hz</p> <p>Duration : 5 sec</p>
	Anti-tripping module pairing failed, or PLC bandwidth overload, or TIC communication loss, or external power meter (PowerTag Resi9, P1, etc.) communication loss	<p>Blinking Red / 1,5Hz</p> <p>From exiting AP mode to communication is restored</p>

18 Recycle

The packaging materials from this equipment can be recycled. The product and all accessories marked with this symbol are electrical and electronic components that must be disposed of separately from household waste. Please help protect the environment by disposing waste in appropriate containers. Thank you for helping to protect the environment.